

2012

The role of glutamatergic inferior olivary teaching signals in the acquisition of conditioned eyeblinks

Andrew J. Carrel
Iowa State University

Follow this and additional works at: <https://lib.dr.iastate.edu/etd>

 Part of the [Neuroscience and Neurobiology Commons](#)

Recommended Citation

Carrel, Andrew J., "The role of glutamatergic inferior olivary teaching signals in the acquisition of conditioned eyeblinks" (2012).
Graduate Theses and Dissertations. 12617.
<https://lib.dr.iastate.edu/etd/12617>

This Dissertation is brought to you for free and open access by the Iowa State University Capstones, Theses and Dissertations at Iowa State University Digital Repository. It has been accepted for inclusion in Graduate Theses and Dissertations by an authorized administrator of Iowa State University Digital Repository. For more information, please contact digirep@iastate.edu.

**The role of glutamatergic inferior olivary teaching signals in the acquisition of
conditioned eyeblinks**

by

Andrew Jennings Carrel

A dissertation submitted to the graduate faculty
in partial fulfillment of the requirements for the degree of

DOCTOR OF PHILOSOPHY

Major: Neuroscience

Program of Study Committee:
Vlastislav Bracha, Major Professor
James Bloedel, Co-Major Professor
Timothy Day
Donald Sakaguchi
Ann Smiley-Oyen

Iowa State University

Ames, Iowa

2012

Copyright © Andrew Jennings Carrel, 2012. All rights reserved.

TABLE OF CONTENTS

LIST OF ABBREVIATIONS	vii
CHAPTER 1: GENERAL INTRODUCTION.....	1
1.1 Dissertation Organization	1
1.2 Introduction.....	2
1.3 Research Hypotheses	5
1.4 Background and Significance	8
1.4.1 Classical conditioning of the eyeblink reflex.	9
1.4.2 Circuits essential for classical conditioning of the eyeblink response. .	11
1.4.3 The controversy regarding the role of the inferior olive in acquisition and expression of conditioned responses.....	12
1.5 References.....	17
CHAPTER 2: A TRIGEMINAL CONDITIONED STIMULUS YIELDS FAST ACQUISITION OF CEREBELLUM-DEPENDENT CONDITIONED EYEBLINKS	23
2.1 Abstract.....	23
2.2 Introduction.....	24
2.3 Material and Methods	26
2.3.1 Subjects.....	26
2.3.2 Surgery.....	26
2.3.3 Training procedures	27
2.3.4 Injection procedures.....	28
2.3.5 Data recording and analysis	29
2.3.6 Histology.....	30
2.4 Results.....	31
2.4.1 General observations	31
2.4.2 The rate of CR acquisition to the vCS and to the tone CS	32

2.4.3 vCS as a second CS	35
2.4.4 Pseudoconditioning.....	35
2.4.5 Cerebellar dependency of vCS-evoked CRs.....	37
2.5 Discussion.....	40
2.6 References.....	46
CHAPTER 3: BLOCKING GLUTAMATE-MEDIATED INFERIOR OLIVARY SIGNALS ABOLISHES EXPRESSION OF CONDITIONED EYEBLINKS BUT DOES NOT PREVENT THEIR ACQUISITION	
3.1 Abstract.....	54
3.2 Introduction.....	55
3.3 Materials and Methods	57
3.3.1 Subjects.....	57
3.3.2 Surgery.....	58
3.3.3 Training procedures	58
3.3.4 Injection procedures and acquisition experiments.....	59
3.3.5 Data recording and analysis.....	61
3.3.6 Histology	62
3.4 Results.....	63
3.4.1 The IO mapping tests – effects of DGG on tone CS-evoked CRs.....	63
3.4.2 CR acquisition while blocking glutamatergic neurotransmission in the IO.....	65
3.4.3 Retention test	68
3.4.4 Post-acquisition training.....	71
3.5 Discussion.....	72
3.6 References.....	78
CHAPTER 4: EFFECTS OF BLOCKING GLUTAMATE NEUROTRANSMISSION IN THE INFERIOR OLIVE ON EYEBLINK CONDITIONING-RELATED INFERIOR OLIVARY SIGNALS – A PILOT STUDY	
	83

4.1 Abstract.....	83
4.2 Introduction.....	84
4.3 Methods	85
4.3.1 Subjects.....	85
4.3.2 Surgery.....	85
4.3.3 Training procedures	86
4.3.4 Injection procedures.....	87
4.3.5 Electrophysiological procedures.....	88
4.3.6 Data recording and analysis.....	88
4.3.7 Histology.....	89
4.4 Results.....	90
4.5 Discussion.....	91
4.6 References.....	93
 CHAPTER 5: THE CEREBELLUM AND EYEBLINK CONDITIONING: LEARNING VERSUS NETWORK PERFORMANCE HYPOTHESES.....	
5.1 Abstract.....	95
5.2 The cerebellar learning hypothesis and classical conditioning of eyeblink responses	96
5.3 The telecommunications network metaphor of eyeblink circuits.....	100
5.4 Tonic interactions in cerebellar circuits.....	106
5.5 Tonic cerebellar interactions in classically conditioned rabbits	107
5.6 Cerebellar learning vs. network performance hypotheses	114
5.7 Dissociating learning from network performance-related phenomena	115
5.8 Conclusion	119
5.9 References.....	121
 CHAPTER 6: THE ROLE OF IN NEURONAL ACTIVITY IN THE CONTROL OF REFLEXIVE AND VOLUNTARY MOVEMENTS.....	
6.1 Abstract.....	129

6.2	Review	129
6.3	References.....	134
CHAPTER 7: BLOCKING GABA _A NEUROTRANSMISSION IN THE		
INTERPOSED NUCLEI: EFFECTS ON CONDITIONED AND		
UNCONDITIONED EYEBLINKS.....		
7.1	Abstract.....	139
7.2	Introduction.....	140
7.3	Results.....	142
7.3.1	General observations	142
7.3.2	Effects of Gabazine and Picrotoxin on CR expression (Experiment #1).146	
7.3.3	Low-Dose Effects.....	149
7.3.4	High-Dose Effects.....	150
7.3.5	Effects of Low-Dose Picrotoxin on CR and UR expression (Experiment #2).....	151
7.3.6	URs to the weak airpuff	153
7.3.7	URs to the strong airpuff and to the light.....	155
7.4	Discussion.....	158
7.4.1	Effects on CR expression	158
7.4.2	Effects on non-associative components of blinking.....	160
7.4.3	Implications for cerebellar control of eyeblinks	161
7.5	Material and Methods	164
7.5.1	Subjects	164
7.5.2	Surgery	164
7.5.3	Training procedures.....	165
7.5.4	Injection procedures	166
7.5.5	Data recording and analysis	167
7.5.6	Histology.....	169
7.6	References.....	170

CHAPTER 8: CONCLUSIONS AND FUTURE DIRECTIONS	174
8.1 Study conclusions	174
ACKNOWLEDGMENTS	177

LIST OF ABBREVIATIONS

aCSF – artificial cerebral spinal fluid

BC – brachium conjektivum

CR – conditioned response

CS – conditioned stimulus

DGG – γ -D-glutamylglycine

GZ – gabazine

IN – interposed nuclei

IO – inferior olive

IR – infrared

LED – light emitting diode

PC – Purkinje cell

PM – premotoneurons

PTX – picrotoxin

SLR – short-latency response

UR – unconditioned reflex

US – unconditioned stimulus

CHAPTER 1: GENERAL INTRODUCTION

1.1 Dissertation Organization

This dissertation investigates the role of the inferior olive in classical conditioning of the eyeblink reflex. The dissertation is written in the alternative format, which contains a general introduction, six research papers, general conclusions, and acknowledgements.

Chapter 1 provides a general introduction to eyeblink classical conditioning, the research hypotheses, the background and significance of the paradigm, and also a literature review. In addition, it delivers a detailed description of the training paradigm, the circuits that mediate eyeblink conditioning, the controversy surrounding the function of the IO, the effects of blocking IO US input, and the functional role of tonic interactions in eyeblink conditioning circuits.

Chapters 2-7 are organized in journal paper format for six manuscripts. Three of the manuscripts are already published, one in which I am the first-author and two others that I co-authored; two manuscripts are currently in review; and the last one describes new preliminary data.

Ch. 2: Carrel, A.J., Zbarska, S., Zenitsky, G.D., and Bracha, V. (2012). A trigeminal conditioned stimulus yields fast acquisition of cerebellum-dependent conditioned eyeblinks. *Behavioural Brain Research*, 226, 189-96.

Ch 3: Carrel, A.J., Zenitsky, G.D., Bloedel, J.R., and Bracha, V. Blocking glutamate-mediated inferior olivary signals abolishes expression of conditioned eyeblinks but does not prevent their acquisition. A paper prepared to be submitted to the *Journal of Neuroscience*.

Ch. 4: Carrel, A.J. Zenitsky, G.D., and Bracha, V. Effects of blocking glutamate neurotransmission in the inferior olive on eyeblink conditioning-related inferior olivary signals.

Ch. 5: Bracha, V., Zbarska, S., Parker, K., Carrel, A., Zenitsky, G., and Bloedel, J. R. (2009). The cerebellum and eye-blink conditioning: learning versus network performance hypotheses. *Neuroscience*, 162(3), 787-96.

Ch. 6: Bracha, V., and Carrel, A.J. (2012). The role of IN neuronal activity in the control of reflexive and voluntary movements. *Cerebellum* (in press, part of multi-author consensus paper titled “What is encoded by the interpositus nucleus? A consensus paper”).

Ch. 7: Parker, K.L., Zbarska, S., Carrel, A.J., and Bracha, V. (2009). Blocking GABA_A neurotransmission in the interposed nuclei: effects on conditioned and unconditioned eyeblinks. *Brain Research*, 1292, 25-37.

Chapter 8 contains general conclusions and recommendations for future directions with this research. References are at the end of each chapter.

1.2 Introduction

Classical conditioning of the eyeblink reflex is a type of motor learning known to be dependent on the intermediate cerebellum. The cerebellum receives information about the conditioned and unconditioned stimuli (CS, US) via mossy fibers and climbing fibers, respectively. The mossy fiber pathway arises from the pontine nuclei while the climbing fiber pathway is derived from axons of neurons located in the inferior olive (IO). It has been proposed that these pathways are both necessary and sufficient to support cerebellum-dependent CR acquisition and expression (Thompson, 1986).

Although the IO has been intensely investigated, its specific role in eyeblink conditioning remains elusive. The cerebellar learning hypothesis states that the IO provides the cerebellum with a “teaching signal” (Marr, 1969; Albus, 1971). Since the IO is the sole source of climbing fiber input to the cerebellum and it provides the cerebellum with information about the US, this input is thought to induce structural and physiological changes within the cerebellum that mediates the cerebellum-dependent CR. If this hypothesis is true, blocking IO US signals should result in the gradual loss of previously learned CRs (i.e., extinction) and failure to acquire new CRs. Some studies that examined this hypothesis show that preventing IO US signals from reaching the cerebellum resulted in what appears to be extinction (McCormick et al., 1985; Mauk et al., 1986; Medina et al., 2002) and failure to learn new CRs (Welsh and Harvey, 1998).

Conversely, other IO lesion and inactivation studies testing the expression of previously learned CRs have shown immediate abolition instead of their gradual loss (Yeo et al., 1986; Zbarska et al., 2007, 2008). Single-unit neuronal recordings in the IN show that blocking glutamate neurotransmission through the IO not only abolishes CRs but it also silences neurons in the IN (Zbarska et al., 2007; 2008). These data indicate that IO inputs to the cerebellum have a broader function than just providing it with a teaching signal for associative learning. In fact, it appears that IO activity has a major impact on the overall tonic activity within the neural network. Thus, it appears that previous studies designed to test the role of the IO in CR acquisition failed to adequately test it because the treatments they used induced a widespread tonic malfunction within the entire network.

Based on this knowledge, the objective of this dissertation was to investigate the role of IO US signals in the acquisition of conditioned eyeblinks. However, before we could begin this task, we first needed to develop a methodology for assessing CR acquisition during pharmacological intervention. Long acquisition experiments spanning many days require multiple pharmacological injections. The more injections that are required, the more likely that one of them will fail and invalidate our acquisition experiment. To limit the likelihood of an injection failure, we needed to find a way to reduce the number of days required for CR acquisition. We succeeded in increasing the speed of CR acquisition using a different CS, specifically a mild airpuff to the ipsilateral vibrissal pad (vCS) (see Chapter 2).

With this new methodology, we commenced our investigation of inferior olivary signaling during CR acquisition. We obtained some very exciting results showing that blocking glutamate signaling in the IO during acquisition to the vCS does not block learning (see Chapter 3). Lastly, we needed to ensure that our IO injections were indeed blocking US signals to the cerebellum. The best evidence would come from recording neuronal activity related to IO firing. Unfortunately, recording activity directly in the IO is a difficult task because it is located in the most ventral area of the medulla oblongata, and implanting recording electrodes in the IO is risky and thus not advised. Fortunately, when neurons in the IO fire action potentials, their activity induces a characteristic electrophysiological signal in the cerebellar cortex called a complex spike (Eccles et al., 1966). This feature allows us to record IO activity directly in the cerebellar cortex. Therefore, we recorded complex spike activity in the eyeblink-related region of the cerebellar cortex (i.e., lobule HVI) before and after glutamate antagonist injections in the IO. We found that our IO injections do block IO-

related complex spikes in the cerebellar cortex (see Chapter 4). Overall, these data indicate that IO signals may not be required for CR acquisition and the “teaching signal” can possibly be delivered to the cerebellum via an alternate route other than through the climbing fiber pathway.

1.3 Research Hypotheses

I. Determine whether a vibrissal conditioned stimulus (vCS) accelerates CR acquisition and whether vCS-evoked CRs are cerebellum-dependent.

The overall goal of this dissertation was to test a primary tenant of the cerebellar learning hypothesis, specifically that the IO provides the cerebellum with information about the US signal. Determining the role of the IO in CR acquisition requires a drug injection in the IO before each training session. Since repeated intracranial microinjections have a relatively high rate of failure, the success of this project would be significantly increased if the CR acquisition period could be shortened and the number of injections reduced.

We hypothesized that a mild vCS would yield much faster CR acquisition than the traditional auditory or visual CS. Moreover, for the vCS to be a viable CS for CR acquisition studies, it must be cerebellar-dependent, similar to CRs evoked by other CS modalities. It is known that manipulations of IN tonic activity using cerebellum-dependent CS modalities produce characteristic behavioral effects. Specifically, IN injections of muscimol produce CR abolition while picrotoxin (PTX) produces short-latency responses. We were able to confirm our hypothesis and also show that vCS-evoked CRs were cerebellum-dependent as described by experiments done in Chapter 2 (Carrel et al., 2012).

II. Determine the role of inferior olivary glutamatergic signals in the acquisition of conditioned eyeblinks.

Most present concepts of eyeblink conditioning presume that learning requires plastic changes in the cerebellum that are induced by inferior olivary US signals. Previous studies that tested the IO's hypothetical function were inconclusive because they could not exclude that the effects of blocking IO signals on learning were caused by a non-specific tonic malfunction of cerebellar circuits.

We developed an innovative approach to block glutamate-mediated IO US signals with the fast glutamate receptor antagonist DGG, while simultaneously compensating for tonic side-effects of the IO signal-blocking treatment by disinhibiting the IN using injections of the GABA-A antagonist PTX. Before deploying this approach, we tested effects of simply blocking IO glutamate on CR acquisition without otherwise compensating for tonic side-effects of this treatment. *We hypothesized that IO US signals are required for CR acquisition, and thus, blocking these signals by injecting the IO with a glutamate receptor antagonist will prevent learning.* Unexpectedly, these experiments led to rejecting our hypothesis and they strongly indicated that, contrary to the cerebellar learning hypothesis, IO US signals are not required for CR acquisition (Chapter 3).

III. Determine whether US signals are actually blocked by the IO DGG injection protocol used during CR acquisition experiments.

Interpreting experiments that addressed research hypothesis II depends on whether injecting the IO with DGG blocks all IO-mediated US signals to the cerebellum. Thus, we initiated studies designed to verify this assumption. Proving or falsifying the putative

teaching role of IO US signals is possible only if single-unit recording in the cerebellar cortex demonstrates that IO DGG blocks all US-related complex spikes of Purkinje cells. *We hypothesized that IO DGG injections would block IO US signals as evidenced by a complete suppression of vCS- and US-related complex spikes in Purkinje cells.* Results of this pilot experiment seem to confirm our hypothesis (Chapter 4).

IV. Determine whether the controversy about effects of blocking GABA_A neurotransmission in interposed nuclei on CR expression could be explained by a drug dose-dependent excitability of interposed nuclear neurons.

Before choosing to examine the role of the IO in CR acquisition as the main subject of my PhD studies, I participated in the investigation of the IN's contribution to CR expression. One of the glaring controversies in the field of eyeblink conditioning arises from contradictory results of disconnecting cerebellar cortical projections to the IN on CR expression. One set of published studies suggested that blocking these GABA-ergic projections abolished CRs, while another set of studies claimed that blocking GABA neurotransmission in the IN shortens CR latencies. Since these results lead to fundamentally different interpretations of IN function, we re-examined this issue.

We hypothesized that in principle these two sets of results could be reconciled by acknowledging changes of tonic activity of IN neurons. If this were the case, we predicted that specific outcomes of blocking cortical projections to the IN should depend on the extent of the GABA-A receptor block. We confirmed this hypothesis in experiments reported in Chapter 7. Since this area of research is only tangentially related to the main subject of this

thesis, Chapter 7 is self-contained and the background for that study is not included in this Introduction.

1.4 Background and Significance

Classical conditioning of the eyeblink reflex is one of the best characterized models of associative/motor learning in mammals. The circuitry involved in this form of learning is well-delineated, and ongoing research focuses on resolving how processing of information in eyeblink conditioning circuits supports learning. It is expected that results of these efforts will lead to greater knowledge about the mechanisms of learning, memory, and the function of the cerebellum. Ultimately, results of this research will help in designing better treatments of human memory and motor control deficits associated with brain injury and pathology.

Although this model has been extensively investigated, the role of the IO in eyeblink conditioning is not well understood. Previous studies of IO signaling during eyeblink conditioning have been inconclusive because traditional methods of blocking IO task-related signals induce a tonic malfunction in the cerebellum, which is manifested by the complete suppression of spontaneous neuronal activity in the IN (for our review of this problem see Chapter 5). Through an innovative approach, our lab has discovered a highly promising way to compensate for this IO-induced tonic malfunction of the cerebellum that will allow us to conclusively test the role of the IO in acquiring CRs.

The following part of this section introduces the eyeblink conditioning paradigm and summarizes the knowledge pertinent to this project.

1.4.1 Classical conditioning of the eyeblink reflex

Delay classical conditioning of the eyeblink reflex entails training rabbits in an associative learning paradigm using two different stimuli. At the start of training, rabbits are presented with a biologically neutral conditioned stimulus (CS), such as a tone, that is followed by (i.e., paired with) and co-terminates with an aversive unconditioned stimulus (US). The US elicits an innate, reflexive, unconditioned response (UR) present in many mammalian species that causes contraction of the eyelids and covering of the cornea by the third eyelid, or nictitating membrane. After the presentation of many paired CS-US trials, the rabbit begins to exhibit a learned conditioned eyeblink response (CR) in anticipation of the upcoming US (Fig. 1). This adaptive response results in the peak of the CR being timed to coincide with the onset of the US (Smith, 1968, Coleman, 1971).

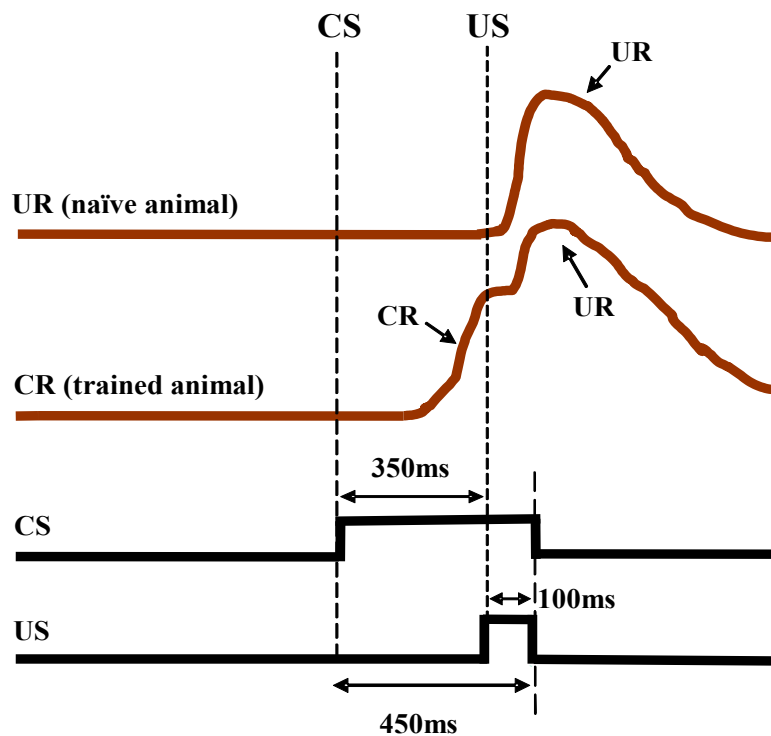

Figure 1. Schematic of the delay classical eyeblink conditioning paradigm. CS denotes onset of a 450-ms conditioned stimulus that co-terminates with a 100-ms unconditioned stimulus (US). Initially, naïve rabbits only exhibit the unconditioned reflex (UR). After repeated, paired CS-US presentations they exhibit conditioned responses (CRs).

Before we could begin testing our hypothesis regarding the IO and CR acquisition, we needed to overcome one technical barrier in our experiment. This barrier is the rate of acquisition using common CS modalities. The most commonly used CS modalities (auditory and visual) generally produce asymptotic learning curves after four to six training days (Clark et al., 1992; Krupa & Thompson, 1997; Welsh & Harvey, 1998; Gruart et al., 2000; Chen & Steinmetz, 2000; Attwell et al., 2001; Nilaweera et al., 2006; Kellet et al., 2010). Such slow learning would likely have limited practical significance under natural conditions. The relatively slow rate of eyeblink conditioning has implications not only for a rabbit's fitness, but also for experimenters. A faster learning rate would be highly desirable, especially in studies designed to interfere with learning by using repeated drug microinjections into specific parts of eyeblink circuits. Since failure of a single microinjection would negatively affect experiments requiring repetitive treatments, shortening the number of training sessions required for CR acquisition would significantly improve the experimental design.

We hypothesized that slow CR acquisition in rabbits could be accelerated with a different CS modality. Under natural conditions, the eye of the rabbit likely encounters harmful objects during locomotion through a complex environment. A potentially effective

“natural” CS could be derived from the vibrissal somatosensory input. Rabbits are endowed with an elaborate vibrissal system and the long and far-projecting whiskers represent an excellent early-warning system for detecting objects approaching their eyes. The vibrissal system in rabbits is very sensitive and its stimulation can elicit reflexive alpha eyeblink responses (Schreurs et al., 1986). Importantly, previous studies have demonstrated that stimulation of mystacial vibrissae could be used in eyeblink conditioning (Schreurs et al., 1986; Das et al., 2001; Troncoso et al., 2004; Leal-Campanario et al., 2006). As described in the Chapter 2, we successfully resolved this issue.

1.4.2 Circuits essential for classical conditioning of the eyeblink response

Many investigators in recent years have been instrumental in determining the relevant circuitry involved in eyeblink conditioning and CR expression (for reviews see (Bracha and Bloedel, 1996, Mauk and Donegan, 1997, Christian and Thompson, 2003, Thompson and Steinmetz, 2009)). The general consensus is that delay eyeblink conditioning is controlled by a reflexive brainstem circuit with the intermediate cerebellar circuitry superimposed on top of the UR reflex circuit (Fig. 2). Although all structures shown in Figure 2 have been shown to be necessary for acquisition and maintenance of CRs, the intermediate cerebellum is thought to contain the sites for plasticity that harbor the “memory trace” for CR production (Thompson, 1986, Bracha and Bloedel, 1996, Attwell et al., 2002a, Ohyama et al., 2002, Christian and Thompson, 2003, Ohyama et al., 2006, Bracha et al., 2009).

According to the prominent hypothesis in the field, the “cerebellar learning hypothesis”, information about the CS is sent to the pontine nuclei, which then send the information via mossy fibers to the cerebellar cortical Purkinje cells and through mossy fiber

collaterals to the interposed nuclei (IN). The sensory signals encoding the US are detected by the spinal trigeminal nucleus, which then sends this information to the IO. The IO, which is the sole source of climbing fiber projections to the cerebellum, relays US information to the cerebellar cortex and via its climbing fiber collaterals, to the IN. The heterosynaptic interaction of the two afferent inputs in the cerebellum is thought to cause a cascade of local cellular changes that result in the Purkinje and nuclear neurons altering their response patterns to the mossy fiber CS information. This change in responsiveness drives the nuclear “CR motor command,” producing CRs. These cerebellar plastic changes have been proposed to be both “necessary and sufficient” for classical eyeblink conditioning (Thompson, 1986).

1.4.3 The controversy regarding the role of the inferior olive in acquisition and expression of conditioned eyeblinks

The role of the IO in eyeblink conditioning has been the subject of much debate over the last quarter century. Elucidating its physiological function in associative and cerebellar motor learning is pivotal for understanding neuronal network operations during CR acquisition and expression. The IO is a large nucleus located in the ventral medulla just caudal to the pons. It can be functionally subdivided into the dorsal accessory olive (DAO), the medial accessory olive, the principal olive, and other subnuclei, such as the dorsal cap of Kooy and the ventrolateral outgrowth (De Zeeuw et al., 1998).

The DAO is the anatomical division that receives most of the attention in studies of eyeblink conditioning because it is thought to relay information about peri-orbital stimulation to the eyeblink-related areas of the cerebellum (Yeo et al, 1985). The axons from neurons in the IO that project to the cerebellum are called climbing fibers. The IO projects to and

synapses with parasagittally-oriented strips of Purkinje cells in the contralateral cerebellar cortex. These climbing fiber projections also give off collaterals that innervate the

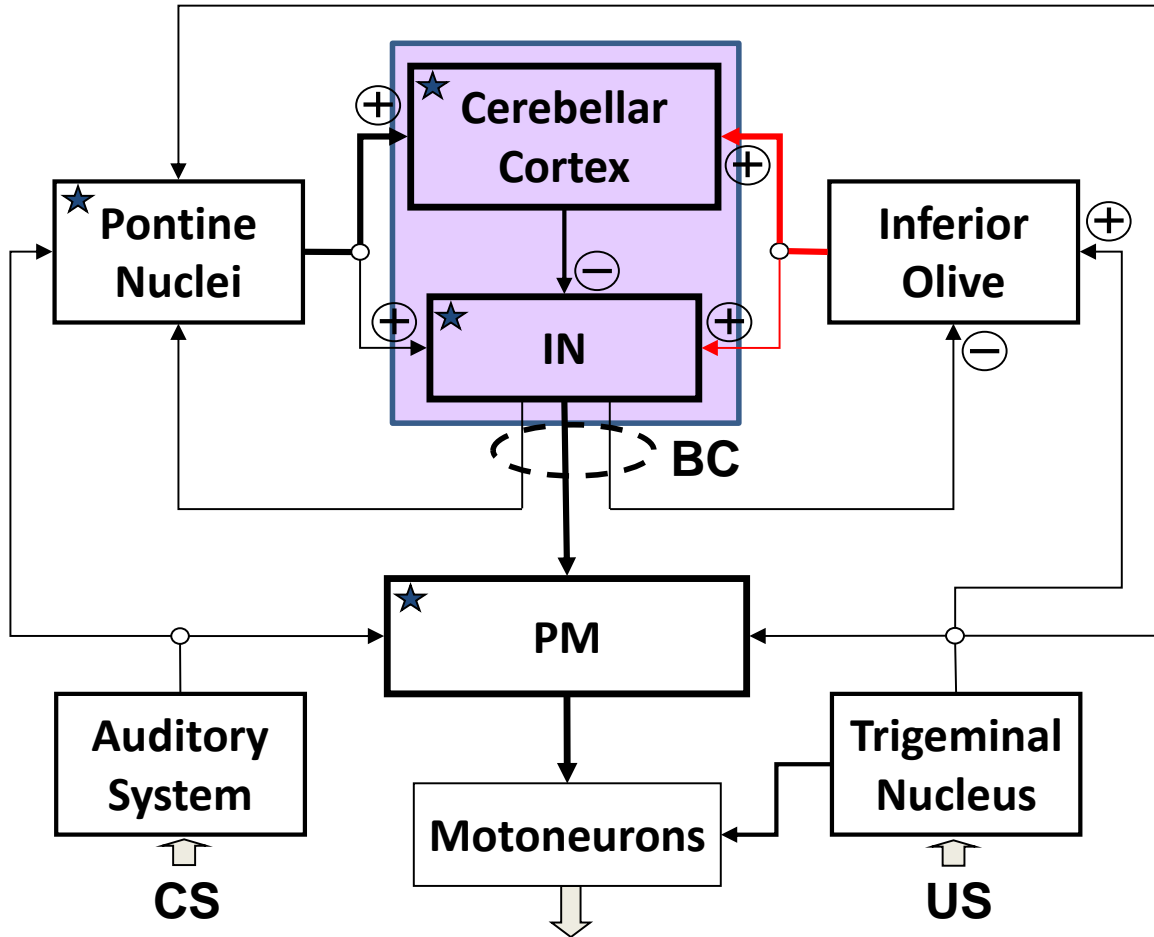

Figure 2. A schematic of intermediate cerebellum-related circuits controlling eyeblink CR acquisition and expression. CS – conditioned stimulus input; US – unconditioned stimulus. Colored box represents intermediate cerebellum (-) inhibitory GABAergic projections; (+) excitatory glutamatergic projections.

cerebellar nuclei within the same zone as the Purkinje cells. The specific IO input, together with the strip of Purkinje cells and accompanying cerebellar nuclei it innervates, form what is called the “cerebellar module” (Ruigrok, 2011). The cerebellar nuclei then project back to that specific area in the IO, completing the topographically organized olivo-cerebellar-olivary loop (Bengtsson & Hesslow, 2006).

This highly organized anatomy partly helped to formulate the original concepts proposed by Marr (1969) and Albus (1971) for the cerebellar learning hypothesis. According to the cerebellar learning hypothesis as it applies to eyeblink conditioning, information about the CS and US reaches the cerebellum via two separate routes. As can be seen in Figure 2, when using an auditory CS, the signal is transmitted by mossy fibers that arise from the pontine nuclei, while information about the US comes from climbing fibers that originate in the IO. The CS and US information converge on cortical Purkinje cells and cerebellar nuclear cells. The heterosynaptic interaction that occurs at these two sites is thought to activate cellular mechanisms that induce plastic changes in these two areas causing the cerebellum to become more responsive to CS input. This increase in responsiveness is hypothesized to drive the cerebellar motor command responsible for generation of the CR.

The plastic changes in the cerebellum that drive CR expression are thought to be induced by the discharge of neurons in the IO. The cerebellar learning hypothesis posits that the IO supplies the cerebellum with a “teaching signal.” A seemingly logical way to test this hypothesis would be to block these IO teaching signals from reaching the cerebellum. If the cerebellar learning hypothesis is true, then blocking these sensory signals in well-trained animals would be similar to turning off the US, which should result in extinction of

previously learned CRs. Moreover, blocking these IO US signals in naïve animals should prevent acquisition of new CRs.

Studies examining the role of the IO in CR expression have produced two competing results. First, as predicted by the cerebellar learning hypothesis, some researchers have shown that lesioning the IO does indeed produce CR extinction (McCormick et al., 1985). Conversely, another group showed not the gradual disappearance of CRs but their immediate abolition (Yeo et al., 1986). Similar to IO lesions, which block all IO activity from reaching the cerebellum, using injections of lidocaine to inactivate IO neurons showed immediate abolition of CR expression (Welsh & Harvey, 1998). Although these studies produced inconsistent results on CR expression, they all showed a failure to acquire new CRs after blocking IO US inputs. In addition, another study testing acquisition following IO NMDA lesions also showed no acquisition of CRs (Mintz et al., 1994).

The problem with the above studies is that silencing the IO, via lesions or inactivations, not only blocks IO task-related signals but also causes a severe cerebellar tonic malfunction (Colin et al., 1980; Montarolo et al., 1982; Batini et al., 1985). This IO manipulation-induced tonic malfunction makes it impossible to conclude whether the failure of rabbits to learn is caused by the absence of IO teaching signals or whether the lack of learning is due to the cerebellar tonic malfunction. Thus, in order to effectively test the role of IO US signals in CR acquisition, we must be able to block these signals while maintaining near-normal spontaneous IO activity to prevent cerebellar tonic malfunction.

One possible way to block IO US signals would be to inject a glutamate antagonist in the IO. It is known that signals relayed from the trigeminal nucleus to the IO are mediated

by glutamate (Lang, 2001). Therefore, blocking glutamate neurotransmission would block the incoming US signal. Although blocking glutamate in the IO does indeed block somatosensory information from the face, the injections also reduce the normal spontaneous firing rate in the IO by approximately 50% (Lang, 2001). Prior experiments in our lab in which glutamate antagonists were injected in the IO and extracellular, single-unit neuronal activity was recorded in the IN show that behaviorally, these injections cause an immediate abolition of previously learned CRs and this immediate abolition is a consequence of a complete tonic suppression of spontaneous firing in the IN (Zbarska et al., 2007; 2008). Hence, even a small reduction in IO firing rate from about 1 Hz under normal conditions to about 0.5 Hz induces a major tonic suppression in the output neurons of the cerebellum.

It appears from the above studies that just blocking glutamate in the IO is not an effective means to test the role of the IO in CR acquisition because these injections also induce cerebellar tonic malfunction. As a result of these findings, we hypothesized that we could design experiments using combined drug injections in the IO. These combined microinjections would entail the injection of a glutamate antagonist to block IO US signals followed by a GABA_A antagonist to block inhibitory inputs that innervate IO neurons. By blocking these GABA_A inputs and thus blocking their inhibitory drive, this treatment could restore IO firing to a more physiologically normal level. This experimental logic parallels a previous experiment showing that injecting the GABA_A antagonist picrotoxin in the IO increases IO activity (Lang, 2002). The initial critical steps in implementing this highly promising method for determining the IO function in eyeblink conditioning are described in Chapters 3 and 4.

1.5 References

Albus JS (1971) Theory of cerebellar function. *Math Biosci* 10: 25-61.

Attwell PJ, Rahman S, Yeo CH (2001) Acquisition of eyeblink conditioning is critically dependent on normal function in cerebellar cortical lobule HVI. *J Neurosci* 21:5715-5722.

Batini C, Billard JM, Daniel, H (1985) Long term modification of cerebellar inhibition after inferior olive degeneration. *Exp Brain Res* 59: 404-409.

Bengtsson F, Hesslow G (2006) Cerebellar control of the inferior olive. *Cerebellum* 5:7-14.

Bracha V, Bloedel JR (1996) The multiple-pathway model of circuits subserving the classical conditioning of withdrawal reflexes. *Acquisition of Motor Behavior in Vertebrates* 175-204.

Carrel AJ, Zbarska S, Zenitsky GD, Bracha V (2012) A trigeminal conditioned stimulus yields fast acquisition of cerebellum-dependent conditioned eyeblinks. *Behav Brain Res* 226:189-196.

Chen G, Steinmetz JE (2000) Microinfusion of protein kinase inhibitor H7 into the cerebellum impairs the acquisition but not the retention of classical eyeblink conditioning in rabbits. *Brain Res* 856:193-201.

Christian KM, Thompson RF (2003) Neural substrates of eyeblink conditioning: acquisition and retention. *Learn Mem* 10:427-455.

- Clark RE, Zhang AA, Lavond DG (1992) Reversible lesions of the cerebellar interpositus nucleus during acquisition and retention of a classically conditioned behavior. *Behav Neurosci* 106:879-888.
- Coleman SR, Gormezano, I. (1971) Classical conditioning of the rabbit's (*Oryctolagus cuniculus*) nictitating membrane response under symmetrical CS-US interval shifts. *J Comp Physiol Psychol* 77:447-455.
- Colin F, Manil J, Desclin, JC (1980) The olivocerebellar system. I. Delayed and slow inhibitory effects: an overlooked salient feature of cerebellar climbing fibers. *Brain Res* 187; 3-27.
- Das S, Weiss C, Disterhoft JF (2001) Eyeblink conditioning in the rabbit (*Oryctolagus cuniculus*) with stimulation of the mystacial vibrissae as a conditioned stimulus. *Behav Neurosci* 115:731-736.
- De Zeeuw CI, Simpson JI, Hoogenraad CC, Galjart N, Koekkoek SK, Ruigrok TJ (1998) Microcircuitry and function of the inferior olive. *Trends Neurosci* 21:391-400.
- Eccles JC, Llinas R, Sasaki K (1966) The excitatory synaptic action of climbing fibres on the purinje cells of the cerebellum. *J Physiol* 182:268-296.
- Gruart A, Morcuende S, Martinez S, Delgado-Garcia JM (2000) Involvement of cerebral cortical structures in the classical conditioning of eyelid responses in rabbits. *Neuroscience* 100:719-730.

Kellett DO, Fukunaga I, Chen-Kubota E, Dean P, Yeo CH (2010) Memory consolidation in the cerebellar cortex. *PLoS One* 5:e11737.

Krupa DJ, Thompson JK, Thompson RF (1993) Localization of a memory trace in the mammalian brain. *Science* 260:989-991.

Krupa DJ, Thompson RF (1997) Reversible inactivation of the cerebellar interpositus nucleus completely prevents acquisition of the classically conditioned eye-blink response. *Learn Mem* 3:545-556.

Lang EJ (2001) Organization of olivocerebellar activity in the absence of excitatory glutamatergic input. *J Neurosci* 21:1663-1675.

Leal-Campanario R, Delgado-Garcia JM, Gruart A (2006) Microstimulation of the somatosensory cortex can substitute for vibrissa stimulation during Pavlovian conditioning. *Proc Natl Acad Sci U S A* 103:10052-10057.

Marr D (1969) A theory of cerebellar cortex. *J Physiol* 202:437-470.

Mauk MD, Donegan NH (1997) A model of Pavlovian eyelid conditioning based on the synaptic organization of the cerebellum. *Learn Mem* 4:130-158.

Mauk MD, Steinmetz JE, Thompson RF (1986) Classical conditioning using stimulation of the inferior olive as the unconditioned stimulus. *Proc Natl Acad Sci U S A* 83:5349-5353.

McCormick DA, Steinmetz JE, Thompson RF (1985) Lesions of the inferior olivary complex cause extinction of the classically conditioned eyeblink response. *Brain Res* 359:120-130.

Medina JF, Nores WL, Mauk MD (2002) Inhibition of climbing fibres is a signal for the extinction of conditioned eyelid responses. *Nature* 416:330-333.

Mintz M, Lavond DG, Zhang AA, Yun Y, Thompson RF (1994) Unilateral inferior olive NMDA lesion leads to unilateral deficit in acquisition and retention of eyelid classical conditioning. *Behav Neural Biol* 61:218-224.

Montarolo PG, Palestini M, Strata P (1982) The inhibitory effect of the olivocerebellar input on the cerebellar Purkinje cells in the rat. *J Physiol* 332:187-202.

Nilaweera WU, Zenitsky GD, Bracha V (2006) Inactivation of cerebellar output axons impairs acquisition of conditioned eyeblinks. *Brain Res* 1122:143-153.

Ruigrok TJ (2011) Ins and outs of cerebellar modules. *Cerebellum* 10:464-474.

Schreurs BG, Jha B, Gormezano I (1986) Classical-Conditioning of the Rabbits Nictitating-Membrane Response to a Piezoceramic Vibrotactile Cs. *Behav Res Meth Instr* 18:359-362.

Smith MC (1968) CS-US interval and US intensity in classical conditioning of the rabbit's nictitating membrane response. *J Comp Physiol Psychol* 66:679-687.

Thompson RF (1986) The neurobiology of learning and memory. *Science* 233:941-947.

Thompson RF, Steinmetz JE (2009) The role of the cerebellum in classical conditioning of discrete behavioral responses. *Neuroscience* 162:732-755.

Troncoso J, Munera A, Delgado-Garcia JM (2004) Classical conditioning of eyelid and mystacial vibrissae responses in conscious mice. *Learn Mem* 11:724-726.

Van Ham JJ, Yeo CH (1992) Somatosensory Trigeminal Projections to the Inferior Olive, Cerebellum and other Precerebellar Nuclei in Rabbits. *Eur J Neurosci* 4:302-317.

Welsh JP, Harvey JA (1998) Acute inactivation of the inferior olive blocks associative learning. *Eur J Neurosci* 10:3321-3332.

Yeo CH, Hardiman MJ, Glickstein M (1985) Classical conditioning of the nictitating membrane response of the rabbit. III. Connections of cerebellar lobule HVI. *Exp Brain Res* 60: 114-126.

Yeo CH, Hardiman MJ, Glickstein M (1986) Classical conditioning of the nictitating membrane response of the rabbit. IV. Lesions of the inferior olive. *Exp Brain Res* 63:81-92.

Zbarska S, Bloedel JR, Bracha V (2008) Cerebellar dysfunction explains the extinction-like abolition of conditioned eyeblinks after NBQX injections in the inferior olive. *J Neurosci* 28:10-20.

Zbarska S, Holland EA, Bloedel JR, Bracha V (2007) Inferior olivary inactivation abolishes conditioned eyeblinks: extinction or cerebellar malfunction? Behav Brain Res 178:128-138.

CHAPTER 2: A TRIGEMINAL CONDITIONED STIMULUS YIELDS FAST ACQUISITION OF CEREBELLUM-DEPENDENT CONDITIONED EYEBLINKS

A paper published in the journal “*Behavioural Brain Research*”¹

A.J. Carrel^{2,3}, G.D. Zenitsky², and V. Bracha^{2,4}

2.1 Abstract

Classical conditioning of the eyeblink response in the rabbit is a form of motor learning whereby the animal learns to respond to an initially irrelevant conditioned stimulus (CS). It is thought that acquired conditioned responses (CRs) are adaptive because they protect the eye in anticipation of potentially harmful events. This protective mechanism is surprisingly inefficient because the acquisition of CRs requires extensive training – a condition which is unlikely to occur in nature. We hypothesized that the rate of conditioning in rabbits could depend on CS modality and that stimulating mystacial vibrissae as the CS could produce CR acquisition faster than the traditional auditory or visual stimulation. We tested this hypothesis by conditioning naïve rabbits in the delay paradigm using a weak air-puff CS (vCS) directed to the ipsilateral mystacial vibrissae. We found that the trigeminal

¹ Reprinted with permission of “*Behavioural Brain Research*”, 2012.

² Department of Biomedical Sciences, Iowa State University.

³ Primary researcher.

⁴ Corresponding author.

vCS yields significantly faster CR acquisition. We next examined if vCS-evoked CRs are dependent on the intermediate cerebellum in the same fashion as CRs evoked by the traditional auditory CS. We found that vibrissal CRs could be abolished by inactivating the cerebellar interposed nuclei (IN) with muscimol. In addition, injections of picrotoxin in the IN shortened the onset latency of vibrissal CRs. These findings suggest that the tone and vCS-evoked CRs share similar cerebellar dependency.

2.2. Introduction

Classical conditioning of the eyeblink reflex in rabbits has proven to be a successful model for the study of associative and motor learning. This model has many benefits, including precise control of experimental variables and an extensive knowledge of circuitry controlling the acquisition and expression of conditioned responses (CRs) [1-6].

During eyeblink conditioning, an initially irrelevant conditioned stimulus (CS, e.g., an audible tone) is paired with an aversive, eyeblink reflex-evoking unconditioned stimulus (US, e.g., airpuff to the cornea). After repeated paired presentations of the two stimuli, subjects acquire conditioned responses (CRs), which are expressed in anticipation of the upcoming US. CRs are considered to be adaptive responses that protect the eye from potentially harmful events. Consistent with this notion, CRs are adaptively timed with the response peak occurring close to the onset of the US [7-10]. Taking into account the protective function of CRs, their acquisition in rabbits is surprisingly slow. The most commonly used CS modalities (auditory and visual) generally produce asymptotic learning curves after four to six training days [11-18]. Such slow learning would likely have limited practical significance under natural conditions. The relatively slow rate of eyeblink

conditioning has implications not only for a rabbit's fitness, but also for experimenters. A faster learning rate would be highly desirable, especially in studies designed to interfere with learning by using repeated drug microinjections into specific parts of eyeblink circuits. Since failure of a single microinjection would negatively affect experiments requiring repetitive treatments, shortening the number of training sessions required for CR acquisition would significantly improve the experimental design.

For rabbit eyeblink conditioning, domesticated breeds (New Zealand White, Dutch-belted) of the European Rabbit (*Oryctolagus cuniculus*) serve as the research model. We hypothesized that slow CR acquisition in rabbits could be accelerated with a different CS modality. Under natural conditions, the eye of the rabbit likely encounters harmful objects during locomotion through a complex environment. European Rabbits are crepuscular animals native to open forest scrub habitats [19], and therefore, approaching objects should be reliably signaled by vision. Indeed, a number of mammalian species (e.g. humans, horses, dogs and cats) display robust and naturally learned, visual menace eyeblinks. However, rabbits don't develop visual menace-triggered blinks, and their rate of CR acquisition to arbitrary visual stimuli is relatively slow [13], similar to the traditional auditory CS. Another potentially effective "natural" CS could be derived from the vibrissal somatosensory input. Rabbits are endowed with an elaborate vibrissal system and the long and far-projecting whiskers represent an excellent early-warning system for detecting objects approaching their eyes. The vibrissal system in rabbits is very sensitive and its stimulation can elicit reflexive alpha eyeblink responses [20]. Importantly, previous studies have demonstrated that stimulation of mystacial vibrissae could be used in eyeblink conditioning [20-23].

In this study, we examined whether vibrissal stimulation could be optimized to yield accelerated CR acquisition. We found that a simple vibrissal airpuff CS (vCS) yields robust and fast CR acquisition both in naïve and previously trained animals. In the second part of this study, we tested whether vCS-evoked CRs depend on cerebellum-related circuits. Here we report that, similar to traditional auditory CS-triggered CRs, vCS-evoked CRs are abolished by inactivating the cerebellar interposed nuclei (IN) with muscimol and their latencies are shortened by elevating IN activity with picrotoxin.

2.3 Material and methods

2.3.1 Subjects

Experiments were performed on 16 male New Zealand White Rabbits (Harlan; Indianapolis, IN) weighing 2.5–3.0 kg (3–4 months old at time of surgery). Rabbits were housed individually on a 12-hour light/dark cycle and provided food and water ad libitum. All experiments were performed in accordance with the National Institutes of Health's “Principles of Laboratory Animal Care” (publication No. 86-23, revised 1985), the American Physiological Society's “Guiding Principles in the Care and Use of Animals,” and the protocol approved by Iowa State University's Animal Care and Use Committee.

2.3.2 Surgery

Surgery was performed using aseptic techniques on naïve rabbits anesthetized with a mixture of ketamine (50 mg/kg), xylazine (6 mg/kg) and acepromazine (1.5 mg/kg). The head was secured in a stereotaxic apparatus with lambda positioned 1.5 mm ventral to bregma. After exposing the skull and affixing three stainless steel anchor screws, a stainless steel injection guide tube (27-gauge thin-wall) was stereotaxically implanted 0.5 mm dorsal

to the expected location of the left anterior IN ($((0.69x+4.8)-x)$ rostral from lambda, x being the horizontal distance between bregma and lambda in mm; 5.3 mm lateral and 13.5 mm ventral to lambda). A 33-gauge stainless steel stylet was inserted into the guide tube between experiments to protect its patency. The guide tube, anchor screws, and a small Delrin (polyoxymethylene thermoplastic) block machined to accommodate an airpuff delivery nozzle and eyeblink sensor were secured in place with dental acrylic. All animals were treated with antibiotics for 5 days while recovering from surgery.

2.3.3 Training Procedures

Prior to surgery, rabbits were adapted to a restraint box (Plas-Labs Inc., Lansing, MI) inside a sound attenuating chamber for 30 min on two consecutive days. Following surgery, rabbits were given one additional day of box adaptation. Rabbits were assigned to one of three groups: the naïve, pseudoconditioning, or 2nd CS group. Animals in the naïve group were trained to a 450-ms weak airpuff CS directed at rows B and C of the left mystacial vibrissae (vCS). The strength of this CS was individually calibrated for each rabbit to an intensity that was just below the threshold for eliciting an alpha response. Initially, the CS intensity was calibrated using a Clippard MAR-1-6 pressure regulator (Clippard Instrument Laboratory, Cincinnati, OH). Later, we switched to another pressure regulator (Bellofram Corporation, Precision Pressure Regulator Type 10LR, Newell, WV) that could more reliably produce the lower CS pressures required in several subjects. Rabbits in the pseudoconditioning group were given an equal number of trials in each session (100 trials of each stimulus) of explicitly unpaired presentations of the vCS and US in a randomized order. Following pseudoconditioning, rabbits were given a retention test consisting of 40 CS-alone

trials. The purpose of the retention test was to obtain a set of measurements which would be compatible with future experiments examining effects of drugs on vCS-evoked CR acquisition. Animals in the 2nd CS group were initially trained to a tone CS. The tone CS was an 85-db, 450-ms, 1-kHz tone, superimposed on a continuous 70-dB white noise background. After acquiring tone-evoked CRs, they were trained to the vCS. All experimental sessions were conducted using the standard delay classical conditioning paradigm until rabbits reached at least 90% CRs for 3 consecutive days. Both CS types co-terminated with a 36-psi (at the source), 100-ms air-puff unconditioned stimulus (US) directed to the left eye. The inter-stimulus interval was 350 ms and the intertrial interval varied pseudorandomly between 15 to 25 sec. Each training session consisted of 100 paired trials per day. During the sessions when the vCS was delivered, a discriminatory airpuff with an intensity of 6 psi was triggered every 7 seconds throughout the duration of the session. This discriminatory airpuff was used to ensure that the rabbit was responding to the vCS and not responding to the sounds of the solenoid or the air exiting the air nozzle.

2.3.4 Injection procedures

Microinjections targeted the IN ipsilateral to the vCS and US. They were delivered through a 33-gauge stainless steel injection needle that was connected to a 10- μ l Hamilton syringe (Hamilton Company, Reno, NV) via transparent Tygon tubing. The Tygon tubing was first filled with ultra-purified water, a small air bubble was pulled into the injection needle, and then the drug was drawn into the tubing. The bubble was used to monitor the volume of drug being injected relative to gradation marks located on the tubing. The injection needle was inserted in the intracranial guide tube before starting the experiment.

Forty pre-injection trials were delivered in order to ensure there were no effects on CR incidence due to needle insertion. The injections were performed manually at a rate of 0.25 μ l/min and after their completion, training continued for an additional 100 trials. If rabbits had less than 85% CRs in the pre-injection period, drug injections were not delivered. Muscimol (Enzo Life Sciences, Switzerland) and picrotoxin (PTX, Sigma-Aldrich, USA) were dissolved in artificial cerebrospinal fluid (aCSF) and the pH of the solution was adjusted to 7.4 ± 0.1 . Injections of picrotoxin (0.83-2.5 nmol) and aCSF were administered at locations where previous 0.5 μ l (1.75 nmol) injections of muscimol completely abolished conditioned eyeblinks. All rabbits were first injected with muscimol to determine the optimal depth for IN injections. Once the optimal site was determined, picrotoxin volume/concentration was individually titrated for each rabbit in order to produce the dose-dependent short latency responses as described in Parker et al. [24]. Following the final PTX experiment, each rabbit was injected with a control injection of an equal volume of aCSF. This order of injections was followed for each rabbit in order to show the effects of IN inactivation, disinhibition, and vehicle on CRs.

2.3.5 Data recording and analysis

Movements of the eyelids were recorded by a wide field-of-view infrared sensor that measures the amount of infrared light reflected from the eye and peri-orbital region [25]. The output of the sensor was amplified, digitized (25 kHz, 12-bit A/D converter), and stored on a custom-made data acquisition system. An infrared video system installed in the experiment chamber was used to monitor behavior of the rabbits and the positioning of the infrared sensor.

Eyeblink data were acquired starting 250 ms before the onset of the CS and continued 800 ms beyond the US onset for a total of 1400 ms in each trial. Eyeblink responses were analyzed offline for the presence of alpha responses, CRs, and URs, each defined by their onset latencies. An alpha response was classified as any response up to 40 ms after CS onset, a CR as an eyelid movement within 41 ms after CS onset up to the US onset, and a UR as any response to the US. Trials containing spontaneous eyeblinks before CS onset were removed from further analyses. The threshold for eyelid movements was set to 5 standard deviations of the baseline signal noise, which corresponded to approximately a 0.15 mm decrease in eyelid aperture. Mean CR incidence and latency were calculated for consecutive blocks of 10 trials. The data were pooled from individual rabbits and statistically analyzed using repeated measures ANOVA followed by individual and simultaneous contrast analyses. All group data were reported as mean \pm standard error of the mean, with an alpha level = 0.05 for declaring significance.

2.3.6 Histology

After all experiments were concluded, rabbits were deeply anesthetized with a cocktail of ketamine (100 mg/kg), xylazine (12 mg/kg), and acepromazine (3 mg/kg). Injection sites were marked by injecting 0.75-1.0 μ l of tissue marking dye. Rabbits were transcardially perfused with 1 L of phosphate buffered saline followed by 1 L of tissue fixative (10% neutral buffered formalin). Excised brains were stored in a solution of 30% sucrose and 10% formalin. Brains were sectioned coronally in 50- μ m slices on a freezing microtome. Subsequently, sections were mounted on gelatin-coated slides, dried, and stained

with luxol blue and neutral red. Injection site locations were identified using bright light microscopy and plotted on standardized sections of the rabbit cerebellum.

2.4 Results

2.4.1 General observations

The vCS was a very effective conditioned stimulus and all rabbits acquired vCS-evoked CRs quickly. One of the features of the vCS is that it can evoke URs when sufficiently strong. The intensity of the vCS was individually adjusted for each rabbit at the onset of training to a sub-threshold level for UR expression. The initial sub-threshold vCS intensity varied from 2-20 psi between rabbits. Due to conditioning-related reflex facilitation [26], this threshold was not constant. As the training progressed, in some animals the initial vCS intensity began to evoke small URs. The transition of these URs into developing CRs formed a two-peak response, reminiscent of the multi-component CRs described in mice [27]. If the vCS UR was observed, the intensity of vCS was further decreased to the sub-threshold level. This procedure ensured that all rabbits developed long-latency, single component CRs to the vCS. The vCS-evoked CRs were unilateral in all animals. Absence of responses to discriminative masking hisses of the air confirmed that acquired CRs were specific to the somatosensory component of the CS.

A total of 15 rabbits were included in the injection experiments. After histological analysis, three rabbits were excluded from the results due to misplaced implants. The histological reconstruction of IN injection sites for the rabbits included in the analyses of pharmacological effects revealed that all rabbits had their injection cannulae either directly in or proximal to the IN (Fig. 1).

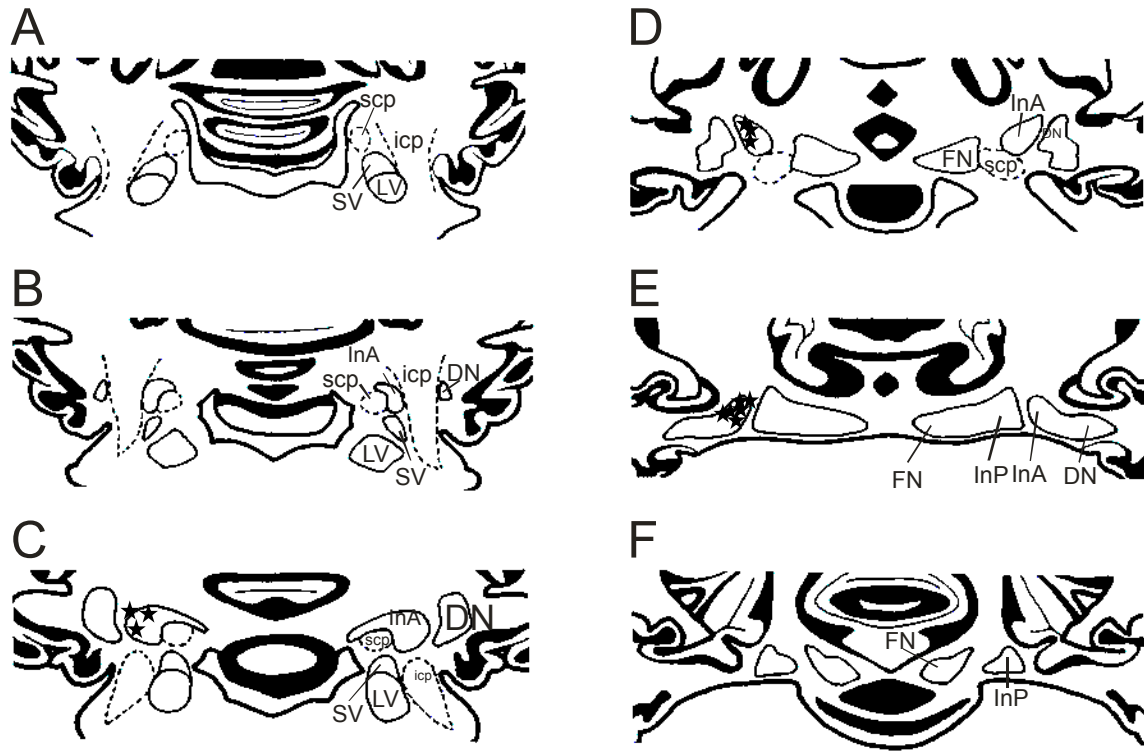

Figure 1. Reconstruction of injection sites in the IN. The identified sites were transferred to a set of standardized coronal sections of the rabbit cerebellum. A-F: Six adjacent sections through the cerebellum, separated by 0.5 mm and arranged in rostral-caudal order with “A” being most rostral. All injection sites were located directly in or proximate to the anterior interposed nucleus and the anterior interposed/dentate nuclear border. InA, anterior interposed nucleus; DN, dentate nucleus; LV, lateral vestibular nucleus; SV, superior vestibular nucleus; InP, posterior interposed nucleus; FN, fastigial nucleus; scp, superior cerebellar peduncle; icp, inferior cerebellar peduncle.

2.4.2 The rate of CR acquisition to the vCS and to the tone CS

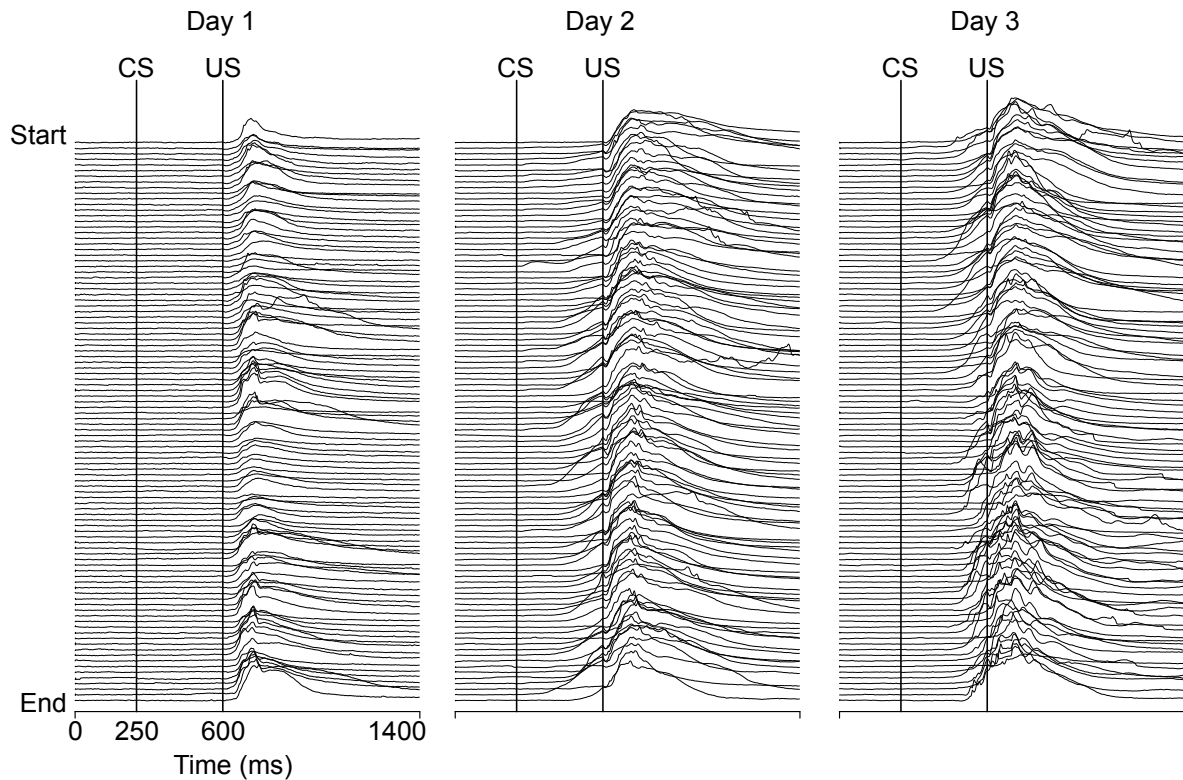

Figure 2. Individual examples of eyeblink stack plots showing acquisition of CRs over three days of vCS training in one naïve rabbit. The first trial for each 100-trial experimental session is at the top of the stack plot and each eyeblink trace represents one trial. (A) During Day 1 of training to the vCS, this rabbit produced only a few small CRs. (B) On Day 2 of training, the rabbit began to exhibit frequent and normal-sized CRs (upward trace deflections between the CS and US markers). Towards the middle of the training session, the CRs show much larger amplitude and the peak of the response becomes time-locked with the US onset. (C) During the third day of training, the rabbit exhibited an asymptotic level of CRs.

Rabbits trained with the vCS acquired CRs in a quick and steady fashion. Figure 2 shows an individual example from each of the first three days of training with paired vCS-US

trials from one of the rabbits in the naïve group. Over the three days of training, rabbits develop substantial, properly-timed CRs whose amplitude peaked at the onset of the US. At the group level, the rate of acquisition in naïve rabbits ($n = 4$) trained with the vCS was considerably faster than naïve rabbits trained to a tone CS ($F_{3,18} = 3.668$, $p = 0.03$) (Fig. 3A). Unlike the tone group, rabbits in the naïve vCS group exhibited a fair number of CRs on Day 1 of training and during Day 2 of training already had a mean CR incidence of $79.2 \pm 17.8\%$. On Day 3, rabbits reached an asymptotic level of conditioned responding, producing a mean CR incidence of $90.0 \pm 5.8\%$. By comparison, rabbits assigned to the naïve tone group ($n = 4$) showed a mean CR incidence of $5.6 \pm 4.3\%$ on Day 2 and $47.3 \pm 11.4\%$ on Day 3 while not reaching an asymptotic level of responding until Day 6, exhibiting a mean CR incidence of $90.1 \pm 0.96\%$. These data show that a weak airpuff to the ipsilateral mystacial vibrissae produces faster CR acquisition than the more commonly used auditory CS modality.

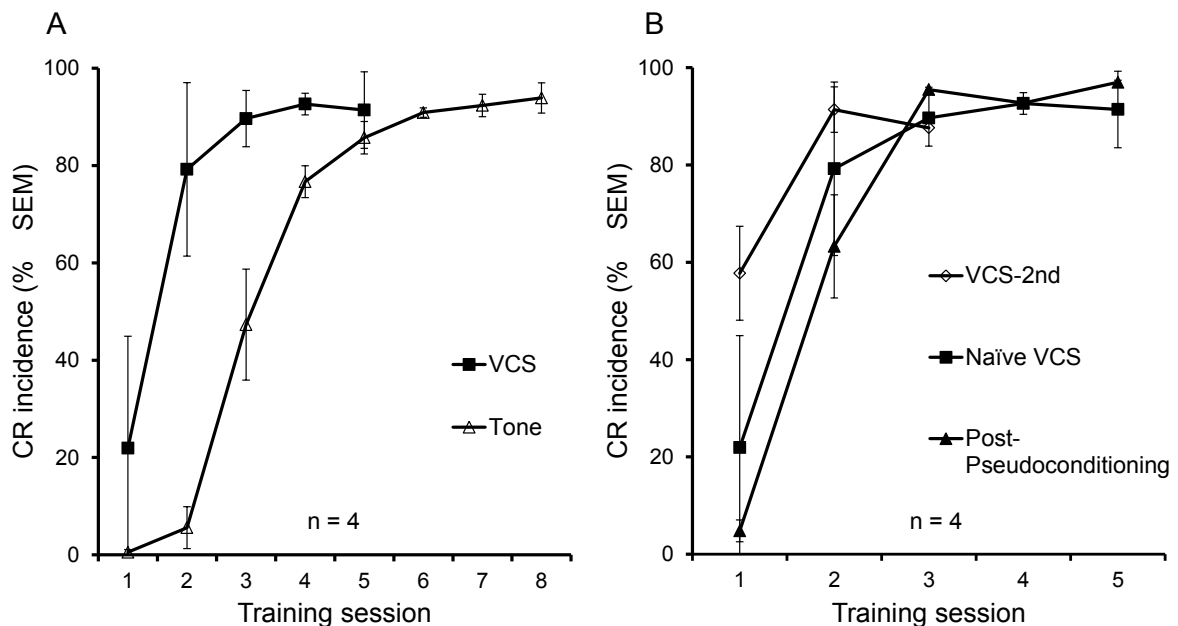

Figure 3. Group learning curves ($n = 4$ for each group) for the vCS and tone CS. The vCS was used for conditioning in naïve rabbits, as a second CS in tone-trained rabbits, and after three days of pseudoconditioning. (A) Training naïve rabbits with the vCS (squares) produces faster CR acquisition than training naïve rabbits with a tone CS (triangles). Rabbits reached the 90% threshold using the vCS in three days while the tone CS group required six days. (B) Training with the vCS in naïve rabbits, as a second CS, or following pseudoconditioning all produced an asymptotic level of responding by Day 3.

2.4.3 vCS as a second CS

In addition to testing the rate of CR acquisition to the vCS in naïve rabbits, we also tested the rate of acquisition in rabbits ($n = 4$) using the vCS as a second CS for a group of rabbits that had already been well trained to a tone CS. Using the vCS as a second CS resulted in acquisition that was numerically faster than vCS in naïve rabbits. The mean CR incidence on Day 2 of 2nd conditioning was already $91.4 \pm 4.7\%$ (Fig. 3B).

2.4.4 Pseudoconditioning

To test whether vCS-evoked eyeblinks are a product of an associative process, a group of rabbits ($n = 4$) was trained with explicitly unpaired vibrissal conditioned stimuli and corneal airpuff unconditioned stimuli. During the three days of pseudoconditioning (Fig. 4), the rabbits did not exhibit any signs of acquiring conditioned responses (maximum CR incidence, $2.57 \pm 1.95\%$, Day 3) relative to the rate of spontaneous eyeblinks. However, pseudo-conditioned rabbits did exhibit normal US-evoked eyeblinks. Following pseudoconditioning, a retention test (40 CS-alone trials) was presented to test for any CRs

acquired during the three days of pseudoconditioning. The mean CR incidence for the retention test was $0.63 \pm 0.62\%$. Following pseudoconditioning, the rabbits were trained with paired vCS-US trials. By means of stimulus pre-exposure, pseudoconditioning may have delayed the onset of learning typically seen on Day 1 during vCS conditioning. Otherwise, rabbits rapidly acquired CRs to the vCS, reaching a mean CR incidence of $95.5 \pm 0.5\%$ by Day 3 of training (Fig. 4). The pseudoconditioning results showed that the vCS-evoked CRs are learned, associative responses.

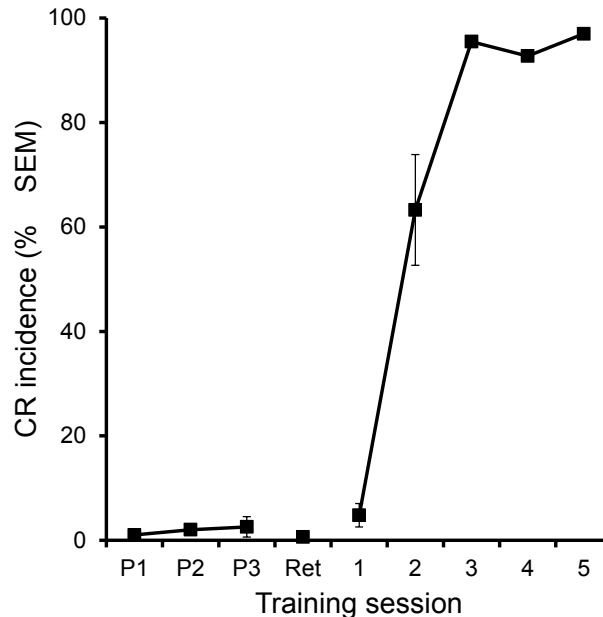

Figure 4. CR incidence for rabbits during pseudoconditioning, retention, and post-pseudoconditioning training. During the three days of pseudoconditioning (P1-P3), rabbits exhibited minimal CRs to the unpaired vCS and showed no signs of learning during the retention test (Ret; 40 vCS-alone trials) performed after pseudoconditioning. Following the retention test, all rabbits showed rapid learning, reaching $\geq 90\%$ CRs on the third day of training with paired vCS-US trials.

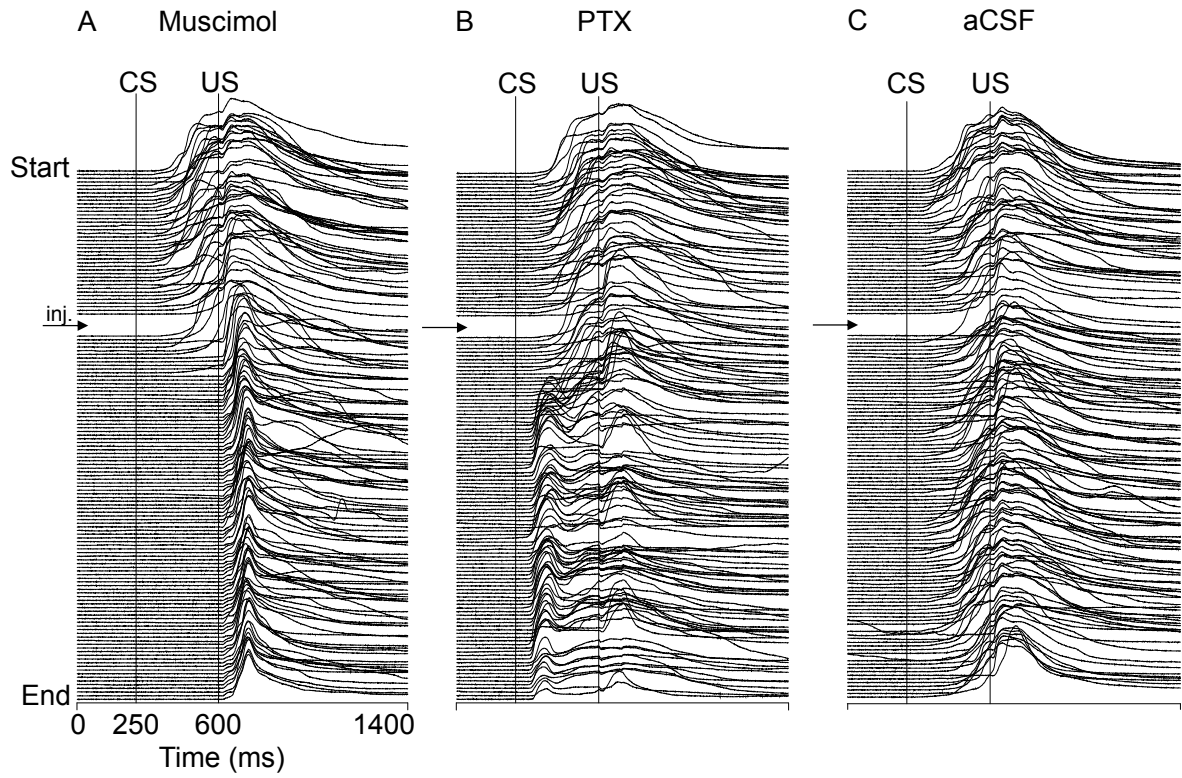

Figure 5. Individual examples of behavioral effects from one rabbit following muscimol and PTX injections in the IN. The experiments start at the top and each horizontal eyeblink trace represents one trial of the 140-trial experimental session. (A) Effect of a muscimol injection (indicated by an arrow in the stack plots). After the injection, CRs (upward deflections of the trace between the CS and US markers) were abolished almost immediately and the effect lasted for the duration of the experiment. (B) PTX shortened the latency of vCS-evoked CRs and this effect also lasted for the remainder of the session. The reduced amplitude of blinks at the end of the experiment is due to PTX-induced tonic eyelid closure. (C) The control experiment in which vehicle (aCSF) had no effect on CRs.

2.4.5 Cerebellar dependency of vCS-evoked CRs

The previous results showed that vibrissal stimulation produces faster acquisition than a tone CS and that CRs exhibited by the vCS are learned, associative responses. To further characterize these responses, we tested whether they are cerebellum-dependent. Specifically, we examined whether inactivating or activating deep cerebellar nuclei would affect vCS-evoked CRs in a way similar to previously reported effects of these manipulations on tone-evoked CRs [24, 28-30].

The first pharmacological test was an injection of the GABA agonist muscimol in the IN. Figure 5A shows an individual example of a muscimol injection in the IN. During the pre-injection trials, the rabbit exhibited adaptively timed, large amplitude vCS-evoked CRs. The vCS-evoked CRs were abolished following the muscimol injection and this effect was maintained for the rest of the experimental session. At the group level, when compared to vehicle injections, muscimol (1.75 nmol) abolished CRs in the post-injection trials ($F_{1, 11} = 957.03$, $p < 0.0001$) (Fig. 6A). The onset of behavioral effects from the injection was rapid as the mean CR incidence was significantly reduced in the initial post-injection block of 10 trials compared to pre-injection CR incidence (contrast- $t_{11} = 3.35$, $p = 0.006$) (Fig. 6A). Muscimol reduced the mean CR incidence from $93.3 \pm 2.25\%$ during the last pre-injection block of trials to $0.83 \pm 0.83\%$ by the fourth post injection block and maintained its effect for the duration of the experiment. In addition to effects on eyeblinks, muscimol injections also visibly decreased UR amplitude and increased the aperture of the palpebral fissure.

After establishing an effective injection site in the IN with muscimol and testing its effects on CRs, an injection of the GABA antagonist PTX was administered at the same location. Injections of PTX (0.83-2.5 nmol) produced several distinct effects on CRs. First

of all, the selected amount of PTX visibly shortened CR latencies (Fig. 5B). This effect was significant at the group level when compared to pre-injection trials ($F_{1, 11} = 37.24, p < 0.0001$). The mean CR latency was reduced from 171.4 ± 12.6 ms in the last pre-injection block of trials to 72.2 ± 14.4 ms by the fourth and to 63.3 ± 5.5 ms by the sixth post-injection block of trials (Fig. 6B). PTX injections had no effect on CR incidence (Figs. 5B and 6A).

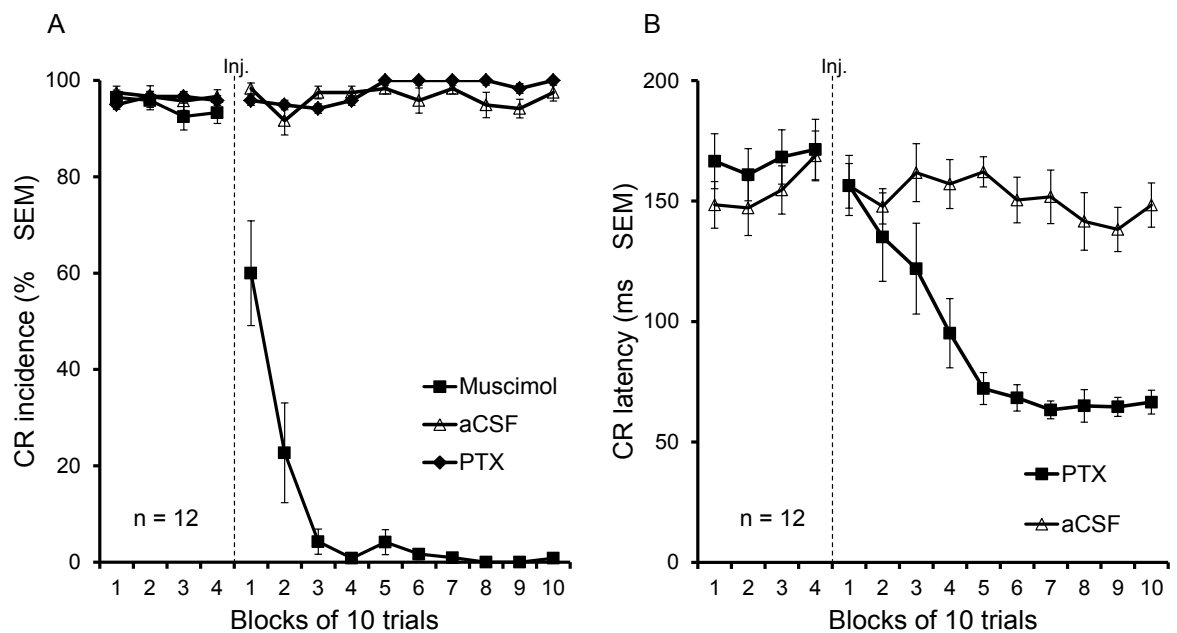

Figure 6. Group data ($n = 12$) for CR incidence (\pm SEM) and latency (\pm SEM) following injections in the IN. Dashed vertical line denotes time of injection for the experiments. (A) The effect of muscimol on CR incidence. An injection of muscimol (squares) immediately impaired CR expression and completely abolished CRs for the remainder of the experiment. The PTX (diamonds) and aCSF injections (triangles) did not significantly affect CR incidence. (B) The effect of a PTX injection on CR latency. The PTX injection (squares) significantly shortened CR latency, compared to a vehicle injection (triangles), for the duration of the experiment.

As previously reported by Parker et al [24], CR latency-shortening doses of PTX increased overall excitability of rabbits, increased tonic eyelid closure, and instead of producing isolated eyeblink movements, rabbits frequently reacted to the CS and US with a whole-head withdrawal away from the air nozzle.

The pharmacological data presented here provide clear evidence that CRs generated by the vCS modality are dependent on the intermediate cerebellum and that, similar to auditory CS-evoked CRs, the incidence and latency of the CRs can be manipulated by up- or down-regulating neuronal activity in the IN.

2.5 Discussion

The objective of the present study was to determine whether a vibrissal CS could produce fast CR acquisition. The results show that using a weak airpuff CS to the ipsilateral mystacial vibrissae does generate faster CR acquisition than the most commonly used auditory stimulation. In addition, we found that vCS-triggered CRs and auditory-triggered CRs share similar cerebellar dependency.

Using an auditory or visual CS, rabbits typically acquire an asymptotic level of CRs after about four to six days [11-18]. In agreement with previous studies [20-22], we confirmed that stimulation of the vibrissae could be used as a CS in eyeblink conditioning. Here, we show that an airpuff that is just sub-threshold in respect to evoking unconditioned eyeblinks is a very effective CS that supports fast acquisition of CRs. A naïve-trained group of rabbits showed well-timed, adaptive blinks while reaching the asymptotic level of CR incidence in three days and in fact, most of the animals exhibited a near-asymptotic level of performance by the second day of training (Figs. 2B and 3A). In addition, rabbits trained

with the vCS as a second CS reached a CR incidence of greater than 90% in just two days. This accelerated conditioning in animals trained with the vCS as a second CS is consistent with the previously reported effects of extended box adaptation [31] and cross-modal “savings” [32-34].

Along with an increase in CR incidence over the course of training, the vCS-evoked CRs showed an increase in amplitude and became more time-locked with the peak of the response coinciding with the onset of the US (Fig. 2). In addition, their topography was similar to tone-evoked CRs. The relatively long latency (Fig. 6B) and adaptive topography of vCS-evoked CRs indicated that they are an outcome of associative learning. However, assessing the potential involvement of non-associative learning required an explicit test. The possibility that the acquisition of responses to the vCS was a result of some non-associative aspect of learning (e.g., sensitization) was eliminated by the pseudoconditioning experiment. The absence of CRs during the three days of the pseudoconditioning control experiment, along with the pseudoconditioning group exhibiting a similar learning curve to the naïve group following the pseudoconditioning training, provides evidence that vCS-evoked CRs are an outcome of associative learning.

Faster acquisition of CRs to the vCS does not necessarily prove that the vCS is the most effective sensory modality for eyeblink conditioning in rabbits. For example, it is known that the rate of conditioning also depends on CS intensity. Scavio and Gormezano [35] reported that rabbits acquire CRs faster with a loud 86-dB tone CS than with a soft 65-dB CS. Thus, the loud 85-dB auditory CS is now the most commonly used CS intensity. Even though an 85-dB tone is fairly loud, one can't exclude that even louder auditory CS

intensities would produce a CR acquisition rate that is comparable to vCS training. However, it is difficult to conceive a common situation in the rabbit's environment where auditory stimuli louder than 85 dB would reliably predict localized danger to the eye. In contrast to this, the vCS intensity used in this study seems to be well within the range of frequently encountered intensities of the rabbit's natural facial stimulation. In fact, several subjects were vCS-trained with 2 psi. This source pressure in our delivery system produces a very weak airpuff and its impact on the vibrissal pad produced barely visible hair deflections. Yet, it yielded fast learning. Since commonly encountered intensities of the vCS yield CR acquisition faster than infrequently occurring strong auditory CS intensities, it appears that the eyeblink conditioning system in the rabbit is comparably better tuned to the facial cutaneous input.

One could argue that even vCS conditioning is too slow to provide rabbits with effective eye protection. After all, most of our rabbits generated a high CR incidence on the second day of conditioning, and by that time they had been exposed to more than 100 conditioning trials! Requiring this many trials to acquire protective responses seems inefficient, especially when compared to other forms of biologically-tuned forms of learning, such as conditioned taste aversion, where a one-trial exposure to the CS and US is sufficient for robust learning [36]. Before drawing conclusions from this comparison, it is important to realize that not all training parameters in typical laboratory eyeblink conditioning sessions are designed to maximize the rate of learning. For example, it is known that fewer than a dozen trials can yield the first CR when rabbits are trained in 1-trial/day sessions (for review see [37]). It appears that the number of training sessions rather than the cumulative number

of trials better describes the rate of eyeblink conditioning. From this perspective, even eyeblink conditioning to a tone CS could be viewed as providing rabbits with some adaptive advantage. Why then do typical eyeblink conditioning sessions run 100, seemingly redundant trials? This “sub-optimal” arrangement is deliberate. Yes, it inflates the cumulative number of trials required for learning, but this cost is outweighed by the numerous advantages offered by repeated sampling. Aside from the possible need to introduce probe-CS or US-alone trials, multiple trials control for potentially large per-trial differences between individual animals, including spontaneous responses, chance events (e.g., postural movements), and the onset and duration of drug effects. Without repeated trials, spurious sampling errors would contaminate the measurements of intervention effects on CR incidence, eyeblink kinematics, and neuronal activity in neurophysiological experiments. The only other option the investigator would be left with is to add many more animals to the experiment.

Why do rabbits learn to respond to the vibrissal CS faster than to auditory or visual conditioned stimuli? It is likely that during evolution neuronal circuits controlling eyeblink conditioning were honed by species-specific selective pressures. European rabbits are prey animals and their visual and auditory systems play a pre-eminent role in teleceptive predator detection. As a consequence, arbitrary visual and auditory stimuli evoke a strong orienting response, part of which is the opposite of an eyeblink–eyelid opening. This competing response has to be habituated first before the animal learns to blink and this process could delay CR acquisition. We presume that the importance of teleception in predator detection is also reflected in the fact that rabbits don’t display visual menace eyeblink responses. The

menace eyeblinks are naturally learned conditioned eyeblinks [38] and if evoked by distant objects, they could interfere with continuity of visual input that is required for effective predator avoidance. Thus, neuronal circuits that control visual menace eyeblinks are present, but not optimized in this species. On the other hand, vibrissae and guard hairs are reliable predictors of nearby and imminently harmful objects, especially during locomotion when the head and eye frequently approach stationary objects, such as vegetation or walls of a rabbit's burrow. In this context, it is not surprising that mammals respond to strong stimulation of the extra-ocular trigeminal region with unconditioned eyeblinks and that eyeblink conditioning circuits in rabbits are well primed for vibrissal sensory input.

Because of the fast rate of CR acquisition, vCS conditioning could be well suited for studies examining effects of drug microinjections on CR acquisition. Typically, experiments of this kind require sequential days of drug injections before each daily training session [16, 17, 30]. Shortening the CR acquisition period would reduce the number of injections and thus the likelihood of injection failure invalidating an experiment. The potential of the vCS for eyeblink conditioning studies is further enhanced by our demonstration that vCS-evoked CRs are cerebellum-dependent. The cerebellar dependency is a hallmark feature of tone and light-evoked CRs in the rabbit. It has been repeatedly shown that inactivating the IN with either lidocaine or muscimol abolishes previously acquired tone or light CS-evoked CRs [28, 39-43]. Similar to these findings, vCS evoked CRs are abolished when the IN is infused with muscimol (Figs. 5A and 6A). Muscimol is a GABA-A agonist which hyperpolarizes neurons, blocking their task-related responses and also their spontaneous activity [28]. On the other hand, picrotoxin is known to reduce task-related modulation of IN neuronal activity

and to dramatically increase their spontaneous firing rate [28]. This effect translates into a dose-dependent effect on the expression of tone CS-evoked CRs. At lower doses, IN PTX shortens CR latencies [24, 44] and at higher doses it abolishes CRs [24]. Similar to the auditory CS, the vCS-evoked CRs have shorter latencies following PTX injections (Figs. 5B and 6B). Surprisingly, we were not able to abolish vCS-evoked responses with higher doses of PTX (data not shown). The most likely explanation for this finding is that high PTX dose-associated responses were not CRs, but rather facilitated unconditioned responses to the vCS. IN PTX is known to facilitate trigeminal unconditioned eyeblinks [24] and it is plausible that the originally sub-threshold intensity of the vCS became supra-threshold following the drug injection. Similar facilitation of tone CS-evoked URs by PTX has been previously reported in naïve rabbits [45].

It is clear that vCS-evoked CRs share similar cerebellar dependency with tone-evoked CRs. Cerebellar involvement in the control of vCS CRs offers a possible explanation to the enhanced speed of learning. Most of the present concepts assume that a significant portion of plastic changes responsible for CR acquisition occur in the cerebellum [18, 30, 46, 47].

Cerebellar learning requires sensory information which is brought via cerebellar mossy fibers from the pontine nuclei and via climbing fibers from the inferior olive. Auditory as well as trigeminal CS information reaches the cerebellum via projections to the pontine nuclei [48-51]. In addition to pontine projections, trigeminal sensory nuclei, including their parts that receive vibrissal information [52, 53], are known to project directly to the cerebellar cortex [51]. It is possible that these direct projections, together with the pontine input, could

facilitate CR acquisition. In addition, information processing in the cerebral cortex could also contribute significantly to vCS conditioning [23].

Overall, the presented data demonstrate that the vCS yields fast acquisition of associative, classically conditioned responses in rabbits and that these CRs share similar cerebellar dependency with tone CS-evoked CRs. These features make the vCS well suited for future investigations of this form of motor learning.

This work was supported by National Institutes of Health grant R01 NS036210.

2.6 References

- [1] Bracha V, Bloedel JR. The multiple-pathway model of circuits subserving the classical conditioning of withdrawal reflexes. *Acquisition of Motor Behavior in Vertebrates*. 1996;175-204.
- [2] Bracha V, Zbarska S, Parker K, Carrel A, Zenitsky G, Bloedel JR. The cerebellum and eye-blink conditioning: learning versus network performance hypotheses. *Neuroscience*. 2009;162:787-96.
- [3] De Zeeuw CI, Yeo CH. Time and tide in cerebellar memory formation. *Curr Opin Neurobiol*. 2005;15:667-74.
- [4] Christian KM, Thompson RF. Neural substrates of eyeblink conditioning: acquisition and retention. *Learn Mem*. 2003;10:427-55.

- [5] Mauk MD, Donegan NH. A model of Pavlovian eyelid conditioning based on the synaptic organization of the cerebellum. *Learn Mem.* 1997;4:130-58.
- [6] Steinmetz JE. Brain substrates of classical eyeblink conditioning: a highly localized but also distributed system. *Behav Brain Res.* 2000;110:13-24.
- [7] Smith MC. CS-US interval and US intensity in classical conditioning of the rabbit's nictitating membrane response. *Journal of comparative and physiological psychology.* 1968;66:679-87.
- [8] Coleman SR, Gormezano, I. Classical conditioning of the rabbit's (*Oryctolagus cuniculus*) nictitating membrane response under symmetrical CS-US interval shifts. *Journal of comparative and physiological psychology.* 1971;77:447-55.
- [9] Lepora NF, Porrill J, Yeo CH, Dean P. Sensory prediction or motor control? Application of marr-albus type models of cerebellar function to classical conditioning. *Front Comput Neurosci.* 2010;4:140.
- [10] Jirenhed DA, Hesslow G. Learning Stimulus Intervals-Adaptive Timing of Conditioned Purkinje Cell Responses. *Cerebellum.* 2011.
- [11] Clark RE, Zhang AA, Lavond DG. Reversible lesions of the cerebellar interpositus nucleus during acquisition and retention of a classically conditioned behavior. *Behav Neurosci.* 1992;106:879-88.

- [12] Krupa DJ, Thompson RF. Reversible inactivation of the cerebellar interpositus nucleus completely prevents acquisition of the classically conditioned eye-blink response. *Learn Mem.* 1997;3:545-56.
- [13] Welsh JP, Harvey JA. Acute inactivation of the inferior olive blocks associative learning. *Eur J Neurosci.* 1998;10:3321-32.
- [14] Gruart A, Morcuende S, Martinez S, Delgado-Garcia JM. Involvement of cerebral cortical structures in the classical conditioning of eyelid responses in rabbits. *Neuroscience.* 2000;100:719-30.
- [15] Chen G, Steinmetz JE. Microinfusion of protein kinase inhibitor H7 into the cerebellum impairs the acquisition but not the retention of classical eyeblink conditioning in rabbits. *Brain Res.* 2000;856:193-201.
- [16] Attwell PJ, Rahman S, Yeo CH. Acquisition of eyeblink conditioning is critically dependent on normal function in cerebellar cortical lobule HVI. *J Neurosci.* 2001;21:5715-22.
- [17] Nilaweera WU, Zenitsky GD, Bracha V. Inactivation of cerebellar output axons impairs acquisition of conditioned eyeblinks. *Brain Res.* 2006;1122:143-53.
- [18] Kellett DO, Fukunaga I, Chen-Kubota E, Dean P, Yeo CH. Memory consolidation in the cerebellar cortex. *PLoS One.* 2010;5:e11737.

- [19] Smith AT, Boyer, A.F. *Oryctolagus cuniculus*. 2008. In: IUCN 2011. IUCN Red List of Threatened Species. Version 2011.
<http://www.iucnredlist.org/apps/redlist/details/41291/0>. Downloaded 30 May 2011.
- [20] Schreurs BG, Jha B, Gormezano I. Classical-Conditioning of the Rabbits Nictitating-Membrane Response to a Piezoceramic Vibrotactile Cs. *Behav Res Meth Instr.* 1986;18:359-62.
- [21] Das S, Weiss C, Disterhoft JF. Eyeblink conditioning in the rabbit (*Oryctolagus cuniculus*) with stimulation of the mystacial vibrissae as a conditioned stimulus. *Behav Neurosci.* 2001;115:731-6.
- [22] Troncoso J, Munera A, Delgado-Garcia JM. Classical conditioning of eyelid and mystacial vibrissae responses in conscious mice. *Learn Mem.* 2004;11:724-6.
- [23] Leal-Campanario R, Delgado-Garcia JM, Gruart A. Microstimulation of the somatosensory cortex can substitute for vibrissa stimulation during Pavlovian conditioning. *Proc Natl Acad Sci U S A.* 2006;103:10052-7.
- [24] Parker KL, Zbarska S, Carrel AJ, Bracha V. Blocking GABAA neurotransmission in the interposed nuclei: effects on conditioned and unconditioned eyeblinks. *Brain Res.* 2009;1292:25-37.
- [25] Ryan SB, Detweiler KL, Holland KH, Hord MA, Bracha V. A long-range, wide field-of-view infrared eyeblink detector. *J Neurosci Methods.* 2006;152:74-82.

- [26] Wikgren J, Ruusuvirta T, Korhonen T. Reflex facilitation during eyeblink conditioning and subsequent interpositus nucleus inactivation in the rabbit (*Oryctolagus cuniculus*). *Behav Neurosci.* 2002;116:1052-8.
- [27] Boele HJ, Koekkoek SK, De Zeeuw CI. Cerebellar and extracerebellar involvement in mouse eyeblink conditioning: the ACDC model. *Front Cell Neurosci.* 2010;3:19.
- [28] Aksenov D, Serdyukova N, Irwin K, Bracha V. GABA neurotransmission in the cerebellar interposed nuclei: involvement in classically conditioned eyeblinks and neuronal activity. *J Neurophysiol.* 2004;91:719-27.
- [29] Ohshima T, Nores WL, Medina JF, Riusech FA, Mauk MD. Learning-induced plasticity in deep cerebellar nucleus. *J Neurosci.* 2006;26:12656-63.
- [30] Krupa DJ, Thompson JK, Thompson RF. Localization of a memory trace in the mammalian brain. *Science.* 1993;260:989-91.
- [31] Hardiman MJ, Ramnani N, Yeo CH. Reversible inactivations of the cerebellum with muscimol prevent the acquisition and extinction of conditioned nictitating membrane responses in the rabbit. *Exp Brain Res.* 1996;110:235-47.
- [32] Kehoe EJ, Holt PE. Transfer across Cs-Us Intervals and Sensory Modalities in Classical-Conditioning of the Rabbit. *Anim Learn Behav.* 1984;12:122-8.

- [33] Holt PE, Kehoe EJ. Cross-Modal Transfer as a Function of Similarities between Training Tasks in Classical-Conditioning of the Rabbit. *Anim Learn Behav.* 1985;13:51-9.
- [34] Campolattaro MM, Freeman JH. Cerebellar inactivation impairs cross modal savings of eyeblink conditioning. *Behav Neurosci.* 2009;123:292-302.
- [35] Scavio MJ, Gormezano, I. . CS intensity effects upon rabbit nictitating membrane conditioning, extinction, and generalization. *Pavlovian journal of biological sciences.* 1974;9:25-34.
- [36] Garcia J, Kimeldorf DJ, Koelling RA. Conditioned aversion to saccharin resulting from exposure to gamma radiation. *Science.* 1955;122:157-8.
- [37] Kehoe EJ, Macrae, M. . Classical conditioning of the rabbit nictitating membrane response can be fast or slow: Implications for Lennartz and Weinberger's (1992) two-factor theory. *Psychobiology.* 1994;22:1-4.
- [38] Bracha V, Zhao L, Wunderlich DA, Morrissy SJ, Bloedel JR. Patients with cerebellar lesions cannot acquire but are able to retain conditioned eyeblink reflexes. *Brain.* 1997;120 (Pt 8):1401-13.
- [39] Welsh JP, Harvey JA. Pavlovian conditioning in the rabbit during inactivation of the interpositus nucleus. *J Physiol.* 1991;444:459-80.

- [40] Bracha V, Webster ML, Winters NK, Irwin KB, Bloedel JR. Effects of muscimol inactivation of the cerebellar interposed-dentate nuclear complex on the performance of the nictitating membrane response in the rabbit. *Exp Brain Res.* 1994;100:453-68.
- [41] Bracha V, Irwin KB, Webster ML, Wunderlich DA, Stachowiak MK, Bloedel JR. Microinjections of anisomycin into the intermediate cerebellum during learning affect the acquisition of classically conditioned responses in the rabbit. *Brain Res.* 1998;788:169-78.
- [42] Attwell PJ, Ivarsson M, Millar L, Yeo CH. Cerebellar mechanisms in eyeblink conditioning. *Ann N Y Acad Sci.* 2002;978:79-92.
- [43] Christian KM, Thompson RF. Long-term storage of an associative memory trace in the cerebellum. *Behav Neurosci.* 2005;119:526-37.
- [44] Garcia KS, Mauk MD. Pharmacological analysis of cerebellar contributions to the timing and expression of conditioned eyelid responses. *Neuropharmacology.* 1998;37:471-80.
- [45] Poulos AM, Nobuta H, Thompson RF. Disruption of cerebellar cortical inhibition in the absence of learning promotes sensory-evoked eyeblink responses. *Behav Neurosci.* 2009;123:694-700.
- [46] Raymond JL, Lisberger SG, Mauk MD. The cerebellum: a neuronal learning machine? *Science.* 1996;272:1126-31.

- [47] Medina JF, Garcia KS, Mauk MD. A mechanism for savings in the cerebellum. *J Neurosci.* 2001;21:4081-9.
- [48] Halverson HE, Freeman JH. Medial auditory thalamic nuclei are necessary for eyeblink conditioning. *Behav Neurosci.* 2006;120:880-7.
- [49] Halverson HE, Freeman JH. Medial auditory thalamic input to the lateral pontine nuclei is necessary for auditory eyeblink conditioning. *Neurobiol Learn Mem.* 2010;93:92-8.
- [50] Campolattaro MM, Halverson HE, Freeman JH. Medial auditory thalamic stimulation as a conditioned stimulus for eyeblink conditioning in rats. *Learn Mem.* 2007;14:152-9.
- [51] Van Ham JJ, Yeo CH. Somatosensory Trigeminal Projections to the Inferior Olive, Cerebellum and other Precerebellar Nuclei in Rabbits. *Eur J Neurosci.* 1992;4:302-17.
- [52] Jacquin MF, Woerner D, Szczepanik AM, Riecker V, Mooney RD, Rhoades RW. Structure-function relationships in rat brainstem subnucleus interpolaris. I. Vibrissa primary afferents. *J Comp Neurol.* 1986;243:266-79.
- [53] Florence SL, Lakshman S. Topography of primary afferent projections in the trigeminal sensory nuclei of rats. *Acta Neurobiol Exp (Wars).* 1995;55:193-200.

CHAPTER 3: BLOCKING GLUTAMATE-MEDIATED INFERIOR OLIVARY SIGNALS ABOLISHES EXPRESSION OF CONDITIONED EYEBLINKS BUT DOES NOT PREVENT THEIR ACQUISITION

A paper prepared to be submitted to the *Journal of Neuroscience*

A.J. Carrel^{5,6}, G.D. Zenitsky⁵, and V. Bracha^{5,7}

3.1 Abstract

The inferior olive (IO) is considered a crucial component of the eyeblink conditioning network. The cerebellar learning hypothesis proposes that the IO provides the cerebellum with a teaching signal that is required for acquisition and maintenance of conditioned eyeblinks. Supporting this concept, previous experiments showed that lesions or inactivations of the IO block CR acquisition. However, these studies were not conclusive. The drawback of these methods is they not only block task-related signals but also completely shut down the spontaneous activity within the IO, which affects in a non-specific manner the remaining eyeblink circuits. We hypothesized that more appropriate and selective blocking of task-related IO signals can be achieved by using injections of glutamate antagonists, which reduce, but do not eliminate the spontaneous activity in the IO. We expected that if glutamate-mediated IO signals are required for learning, their blocking during training sessions should prevent CR acquisition. To test this prediction, rabbits were

⁵ Department of Biomedical Sciences, Iowa State University.

⁶ Primary researcher.

⁷ Corresponding author.

trained to acquire conditioned eyeblinks to a mild vibrissal airpuff as the conditioned stimulus (vCS) while injections of the glutamate antagonist DGG were administered to the IO. Remarkably, even though IO DGG injections suppressed CRs during training sessions, the post-acquisition retention test revealed that CR acquisition was not abolished. The ability to acquire CRs with IO US signals blocked or severely suppressed suggests that mechanisms responsible for CR acquisition are extremely robust and probably less dependent on IO task-related signals than previously thought.

3.2 Introduction

In the delay classical conditioning paradigm, a biologically neutral conditioned stimulus (CS) is presented with an aversive unconditioned stimulus (US) whereby the timing of the two stimuli overlap and co-terminate. After several training sessions, animals learn to respond to the CS with anticipatory conditioned responses (CRs). The cerebellar learning hypothesis proposes that the inferior olivary nucleus (IO) supplies the cerebellum with information about the US in the form of a “teaching signal” that is essential for learning and maintenance of CRs. This hypothesis was supported by showing that neurons in the IO fire in response to presentation of the US (Gellman et al., 1983; Weiss et al., 1993). Moreover, previous acquisition studies in which the IO was lesioned or inactivated using lidocaine show that rabbits can’t acquire new CRs in the absence of IO US signals (Yeo et al., 1986; Mintz et al., 1994; Welsh and Harvey, 1998).

The weakness of these acquisition studies is that they did not account for tonic cerebellar malfunction that is known to be triggered by inferior olivary lesions or inactivation (Colin et al., 1980; Montarolo et al., 1982; Batini et al., 1985). Thus, in these studies, it’s

unknown whether blocked IO sensory signals or the tonic malfunction of cerebellar circuits was the primary cause of the rabbits' failure to learn. Ideally, to test the role of IO US signals in CR acquisition, one needs to block these signals without affecting IO and cerebellar spontaneous activity.

It has been established that signals relayed to the IO from the trigeminal nucleus are mediated by glutamate (Lang, 2001). Therefore, blocking glutamate neurotransmission in the IO could be the solution for blocking IO sensory signals. Even though blocking glutamate in the IO does block somatosensory responses, this treatment also reduces the firing rate of the IO (Lang, 2001). Interestingly, even this relatively modest reduction of IO firing rate still has a major non-specific effect on cerebellar nuclear output neurons – it silences them (Zbarska et al, 2007; 2008). These findings suggest that successfully testing IO signal function requires methods that block IO US signals while compensating for tonic changes in the cerebellum. We hypothesized that the negative side effects on network performance caused by blocking glutamate neurotransmission could be mitigated by targeting GABA receptors to disinhibit the IO. Toward this end, we designed experiments using combined drug injection protocols that would block glutamate signaling in the IO while concomitantly restoring IO spontaneous neuronal activity to a near-normal level.

As an initial step in that direction, we examined the effects of an uncompensated glutamate antagonist in the IO on CR acquisition. The present study utilized a “second” conditioning protocol. Rabbits were first trained using a tone CS until they reached an asymptotic level of CRs. Following tone training, injections of the glutamate antagonist γ -D-Glutamylglycine (DGG) were administered to the IO. The advantage of this experimental

design is that it provides a functional test for DGG injections, which at the correct location and in the proper dose abolishes previously learned CRs. Following the DGG mapping experiment, rabbits underwent training using a weak airpuff to the vibrissal pad (vCS) while blocking IO glutamate. Similar to tone-evoked CRs, vCS-evoked CRs are cerebellum-dependent (Carrel et al., 2012). In addition, the rapid acquisition of CRs using the vCS reduces the duration of training, which correspondingly reduces the likelihood of a possible drug injection failure during multiple drug administrations. Due to the cumulative nature of CR acquisition, training sessions cannot be repeated, so one compromised injection that fails to block CR expression could invalidate the experiment.

We hypothesized that blocking glutamate neurotransmission in the IO should prevent acquisition of new CRs because IO US signals will be blocked and also because of the IO manipulation-induced cerebellar tonic malfunction. These tonic changes are accompanied by a complete suppression of interposed nuclear activity (Zbarska et al., 2007; 2008), which when induced by direct IN inactivation is known to block learning (Krupa, Thompson, & Thompson, 1993). Here, we report that contrary to our expectations, injections of DGG in the IO that reliably abolished previously learned tone-evoked CRs did not prevent acquisition of CRs to the vCS. These findings indicate that the mechanism of CR acquisition is extremely robust because it can still effectively function with IO US signals blocked (or at minimum severely diminished) and in the presence of IO DGG-induced cerebellar tonic malfunction.

3.3 Materials and Methods

3.3.1 Subjects

Experiments were performed on 12 male New Zealand White Rabbits (Harlan; Indianapolis, IN) weighing 2.5–3.0 kg (3–4 months old at time of surgery). Rabbits were housed individually on a 12-hour light/dark cycle and provided food and water *ad libitum*. All experiments were performed in accordance with the National Institutes of Health's "Principles of Laboratory Animal Care" (publication No. 86-23, revised 1985), the American Physiological Society's "Guiding Principles in the Care and Use of Animals," and the protocol approved by Iowa State University's Animal Care and Use Committee.

3.3.2 Surgery

Surgical implantations were performed using aseptic techniques on naïve rabbits anesthetized with a mixture of ketamine (50 mg/kg), xylazine (6 mg/kg) and acepromazine (1.5 mg/kg). The head was secured in a stereotaxic apparatus with lambda positioned 1.5 mm ventral to bregma. After exposing the skull and affixing three stainless steel anchor screws, a stainless steel injection guide tube (27-gauge thin-wall) was implanted stereotaxically targeting the dorsal aspects of the right IO ($((0.69x + 4.5) - x)$ rostral from lambda, x being the horizontal distance between bregma and lambda in mm; 1.0 mm lateral; and 23.4 mm ventral from lambda). In order to protect its patency, a 33-gauge stainless steel stylet was inserted in the guide tube between experiments. The guide tube, anchor screws, and a small Delrin block designed to accommodate an airpuff delivery nozzle and eyeblink sensor were secured in place with dental acrylic. All animals were treated with antibiotics for 5 days while recovering from surgery.

3.3.3 Training procedures

Prior to surgery, rabbits were adapted to a restraint box (Plas-Labs Inc., Lansing, MI) inside a sound-attenuating chamber for 30 min on two consecutive days. After recovery from surgery, rabbits were given one additional day of box adaptation. Box-adapted rabbits were assigned to either the experimental or control group and conditioned using the delay classical conditioning paradigm until they reached $\geq 90\%$ conditioned responses (CRs) for 3 consecutive training days. The initial conditioned stimulus (CS) was a 450-ms, 85-dB, 1-kHz tone, superimposed on a 70-dB white noise background. The tone CS co-terminated with a 100-ms, 36-psi (at the source) unconditioned stimulus (US) directed at the left cornea. The inter-stimulus interval was 350 ms and the inter-trial interval varied pseudorandomly between 15-25 sec. Each training session consisted of 100 paired trials per day.

3.3.4 Injection procedures and acquisition experiments

Intra-cranial microinjections were delivered using a 33-gauge stainless steel injection needle that was connected to a 10- μ l Hamilton syringe (Hamilton Company, Reno, NV) via transparent Tygon tubing. The Tygon tubing was first filled with ultra-purified water, then a small air bubble was pulled into the injection needle, followed by the drug being drawn into the tubing. The movement of the bubble was used to monitor the volume of drug being injected relative to gradation marks located on the tubing. An AMPA/kainate and NMDA receptor antagonist, γ -D-Glutamylglycine (DGG, Tocris Bioscience, USA), was dissolved in artificial CSF (aCSF) and its pH was adjusted to 7.4 ± 0.1 . The injections were performed manually at a rate of 0.25 μ l/min.

Determining IO injection sites. In the first section of the present study, rabbits were subjected to functional mapping sessions in which they were injected with DGG (0.5 μ l, 100

nmol/ μ l) to determine the precise location and amount of DGG required to quickly abolish previously learned tone-evoked CRs. The injection needle was inserted in the intra-cranial guide tube before starting the experiment. Rabbits were presented with 40 pre-injection trials to ensure there were no effects on CR performance due to needle insertion. Following the drug injection, an additional 160 post-injection trials were presented to the rabbit. In the first mapping experiment, DGG was injected at a depth that corresponded to the tip of the injection guide tube. Subsequent DGG injections were given every 20 trials until we observed a drug effect or a maximum of 2 μ l had been injected. If no drug effect on CR incidence was observed, the injection needle was advanced ventrally an additional 0.5 mm the following day and the mapping session was repeated. This daily advancement was performed until DGG injections completely abolished CRs or until the needle had reached the base of the skull. The volume required for maintenance of DGG-induced abolition for the 160 post-injection trials ranged from 0.5 μ l – 2.0 μ l.

vCS acquisition training. After determining the effective injection site for DGG to abolish tone-evoked CRs, the main part of the study commenced. This began with calibration of the 450-ms weak airpuff CS directed at rows B and C of the left mystacial vibrissae (vCS) that would be used for the acquisition protocol. The strength of this CS was individually calibrated for each rabbit (2-20 psi) to an intensity that was just below the threshold for eliciting an alpha response (for a more detailed description, see Carrel et al., 2012). Once the intensity of the vCS was determined, the acquisition experiment began. This part of the study entailed three days of acquisition with 100 paired vCS-US trials per day. Each vCS acquisition training session started with the injection needle inserted,

followed by 10 tone CS-US presentations to test for possible needle insertion effects. The experimental group received IO DGG injections prior to each vCS acquisition session and the control group received IO vehicle injections. Rabbits were injected with double the volume of DGG that was needed to abolish CRs in the mapping experiment. This same volume was administered in vehicle injections. After a waiting period equivalent to the previously established latency for DGG-induced CR abolition, paired tone CS-US trials were resumed to confirm DGG-induced abolition of previously learned tone-evoked CRs. During these post-injection tone trials, CRs were considered abolished when no more than 1 CR per 10-trial block was present. In rare instances, an additional DGG injection was given to insure complete abolition of CRs. Once CRs were abolished, acquisition training using the vCS began. The vCS acquisition sessions were divided into blocks of 10 trials consisting of 9 vCS-US trials and 1 tone CS-US trial. These tone trials represent probe trials presented to assess whether previously learned tone CS-evoked CRs remained reliably abolished throughout the whole training session. These procedures were repeated in all vCS training sessions.

Retention test. Following 3 days of vCS acquisition, rabbits were given one day of rest to recover from the DGG effects. One day after resting, subjects were given a retention test. The retention test consisted of 40 vCS-alone trials to assess whether any learning occurred during the previous training under the influence of IO DGG. Immediately following the retention test, rabbits were trained in daily sessions of 100 paired vCS-US trials until they reached an asymptotic level of responding for 3 days.

3.3.5 Data recording and analysis

Movements of the eyelids were recorded using a wide field-of-view infrared sensor that measures the amount of infrared light reflected from the eye and peri-orbital region (Ryan et al., 2006). The output of the sensor was amplified, digitized (25 kHz, 12-bit A/D converter), and stored using a custom-made data acquisition system. An infrared video system installed in the experiment chamber was used to monitor behavior of the rabbits and for positioning the infrared sensor.

Eyeblick data were acquired starting 250 ms before onset of the CS and ending 800 ms beyond the US onset for a total of 1400 ms in each trial. Eyeblick responses were analyzed offline for the presence of alpha responses, CRs, and URs, each defined by their onset latencies. An alpha response was classified as any response up to 80 ms after CS onset, a CR as an eyelid movement occurring from 81 ms after CS onset up to the US onset, and a UR as any response after the US onset. Trials containing spontaneous eyeblinks before CS onset were removed from further analyses. The threshold for eyelid movements was set to 5 standard deviations of the baseline signal noise, which corresponded to approximately a 0.15 mm decrease in eyelid aperture. Mean CR incidence and latency were calculated for consecutive blocks of 10 trials. The data were pooled from individual rabbits and statistically analyzed using repeated measures ANOVA followed by individual and simultaneous contrast analyses. All group data were reported as mean \pm standard error of the mean, with an alpha level = 0.05 for declaring significance.

3.3.6 Histology

After all experiments were completed, rabbits were deeply anesthetized with a cocktail of ketamine (100 mg/kg), xylazine (12 mg/kg), and acepromazine (3 mg/kg).

Injection sites were marked by injecting 0.75-1.0 μ l of tissue-marking dye. Rabbits were transcardially perfused with 1 L of phosphate-buffered saline followed by 1 L of tissue fixative (10% neutral-buffered formalin). Excised brains were stored in a solution of 30% sucrose and 10% formalin. Brains were sectioned coronally in 50- μ m slices on a freezing microtome. Subsequently, sections were mounted on gelatin-coated slides, dried, and stained with luxol blue and neutral red. Injection site locations were identified using bright light microscopy and plotted on standardized sections of the rabbit cerebellum.

3.4 Results

Overall, blocking IO glutamatergic signals while training rabbits to a vibrissal CS did not block learning as demonstrated by the post-acquisition retention test. This was surprising because during the acquisition sessions, CR expression was abolished. In agreement with this result, the vCS rabbits showed a near asymptotic level of CRs on Day 1 of post-acquisition training.

A total of 12 rabbits were included in the acquisition experiments. One rabbit was excluded from the study due to consistent URs to the lowest intensities of the vCS. Another rabbit was euthanized due to his health condition. After histological analysis, one additional subject was excluded from the results due to a misplaced implant. Thus, five animals were included in the experimental group and four in the control group. The histological reconstruction of IO injection sites for the remaining 9 animals revealed that all subjects had their injections administered either directly in or proximal to the rostral part of the dorsal accessory IO (Fig. 1).

3.4.1 The IO mapping tests - effects of DGG on tone CS-evoked CRs

Determining the optimal depth for IO injections and the dose of DGG required for blocking IO signals in the eyeblink-related area of the IO was conducted in rabbits pre-trained with the tone CS. The suppression of tone CS-evoked CRs served as a functional index of an adequate DGG injection. Prior to the DGG injection, all rabbits exhibited well timed, large amplitude CRs to the tone CS (Fig. 2A). After the DGG administration, CR performance quickly deteriorated and CRs were abolished for the remainder of the

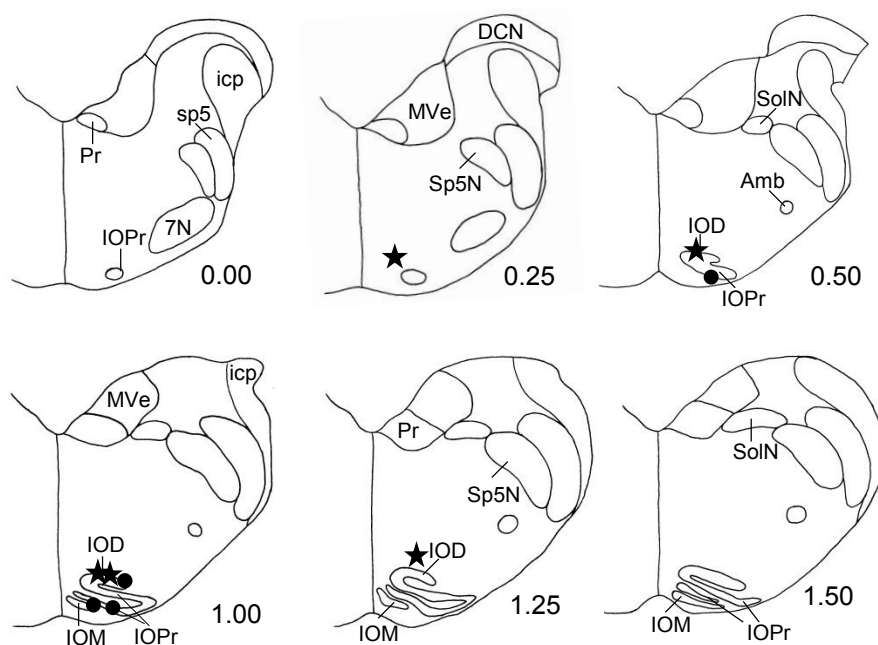

Figure 1. Locations of injection sites in the inferior olive (IO) for the experimental group (black stars) and the control animals (black circles). The identified sites for individual animals were transferred to a set of standardized coronal sections of the rabbit medulla arranged in rostral-to-caudal order with “A” being the most rostral. The numbers on the lower right side of each section represent the anterior-posterior distance in millimeters of each section as measured from the rostral part of the dorsal accessory IO. All injection sites were located in or adjacent to the rostral portion of the inferior olivary complex. IOD, dorsal

accessory inferior olive; IOM, medial inferior olive; IOPr, principal inferior olive; Sp5N, spinal trigeminal nucleus; sp5, spinal trigeminal tract; Pr, prepositus hypoglossal nucleus; 7N, facial nucleus; icp, inferior cerebellar peduncle; MVe, medial vestibular nucleus; SolN, solitary nucleus; Amb, ambiguous nucleus; DCN, dorsal cochlear nucleus.

experiment (Figs. 2A, 3). This suppression of CR incidence was significant when compared to the pre-injection performance ($F_{1,14} = 1574.2$, $p < 0.0001$) or to control injections of vehicle ($F_{1,14} = 406.3$, $p < 0.0001$). The effect of DGG on CR incidence in the control and experimental groups was similar (Fig. 3) ($F_{1,14} = 0.96$, $p = 0.34$). This data shows that blocking glutamate neurotransmission in the IO with DGG reliably abolished tone CS-evoked CRs.injection.

3.4.2 CR acquisition while blocking glutamatergic neurotransmission in the IO

After finding the optimal IO injection location and dose of DGG required to abolish previously learned CRs, the acquisition experiment was conducted. It is important to note that rabbits in the experimental group received a dose of DGG that was double the volume needed to abolish CRs during the IO mapping phase of the experiment. This drug excess was used to increase the likelihood that all glutamate signaling in the eyeblink-related portions of the IO was indeed blocked. During the acquisition phase of the study, rabbits were injected either with DGG or vehicle before each training session and trained to the vCS for three days. This DGG treatment abolished CRs to both modalities of the CS. Figures 4A and 4C show individual examples of eyeblink responses to the vCS on Day 3 of acquisition, contrasting the effects of DGG and aCSF. The rabbit in the experimental group exhibited

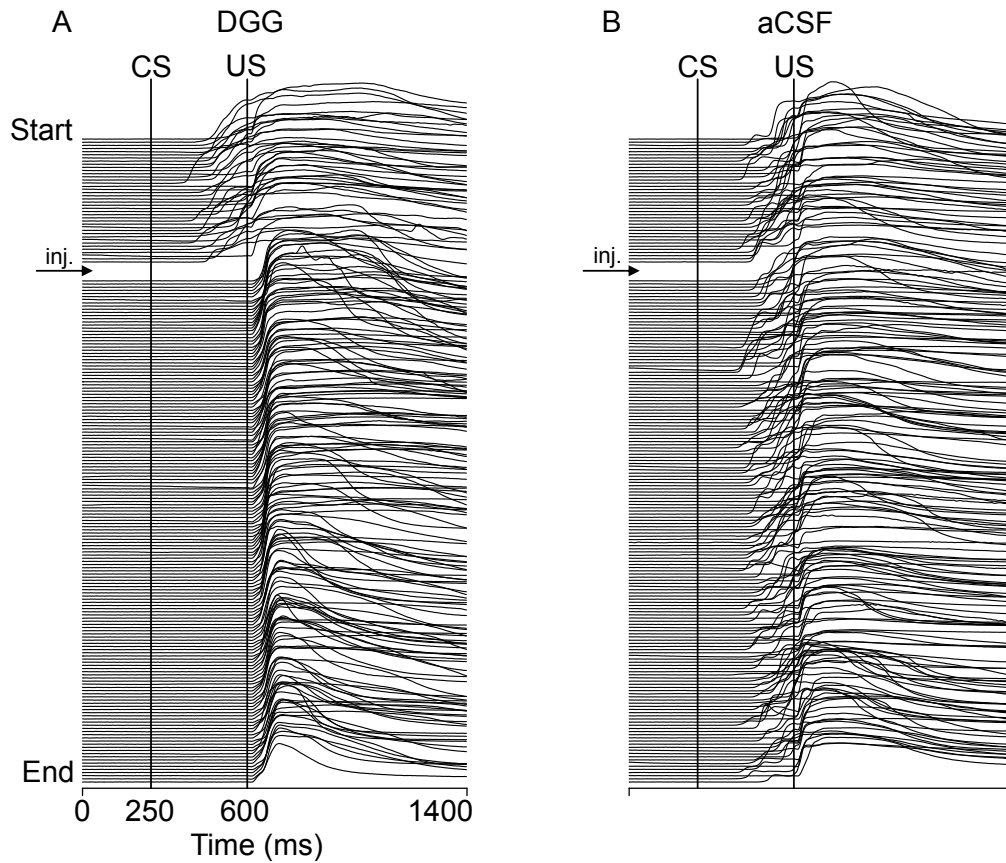

Figure 2. Individual examples from the same animal showing the effects of injecting DGG or vehicle in the IO on expression of tone CS-evoked CRs in the IO mapping part of the study. Each experiment starts at the top and each blink trace represents one trial of the 200-trial experiment. Upward deflections of the trace between the vertical CS and US markers denote conditioned eyeblinks. The timing of injections is shown by an arrow in each stack plot. (A) The effect of DGG injected in the IO following 40 pre-injection trials. DGG immediately abolished CRs and this effect lasted for the remainder of the experiment. (B) Control experiment in which aCSF was injected in the IO. The vehicle had no effect on CRs.

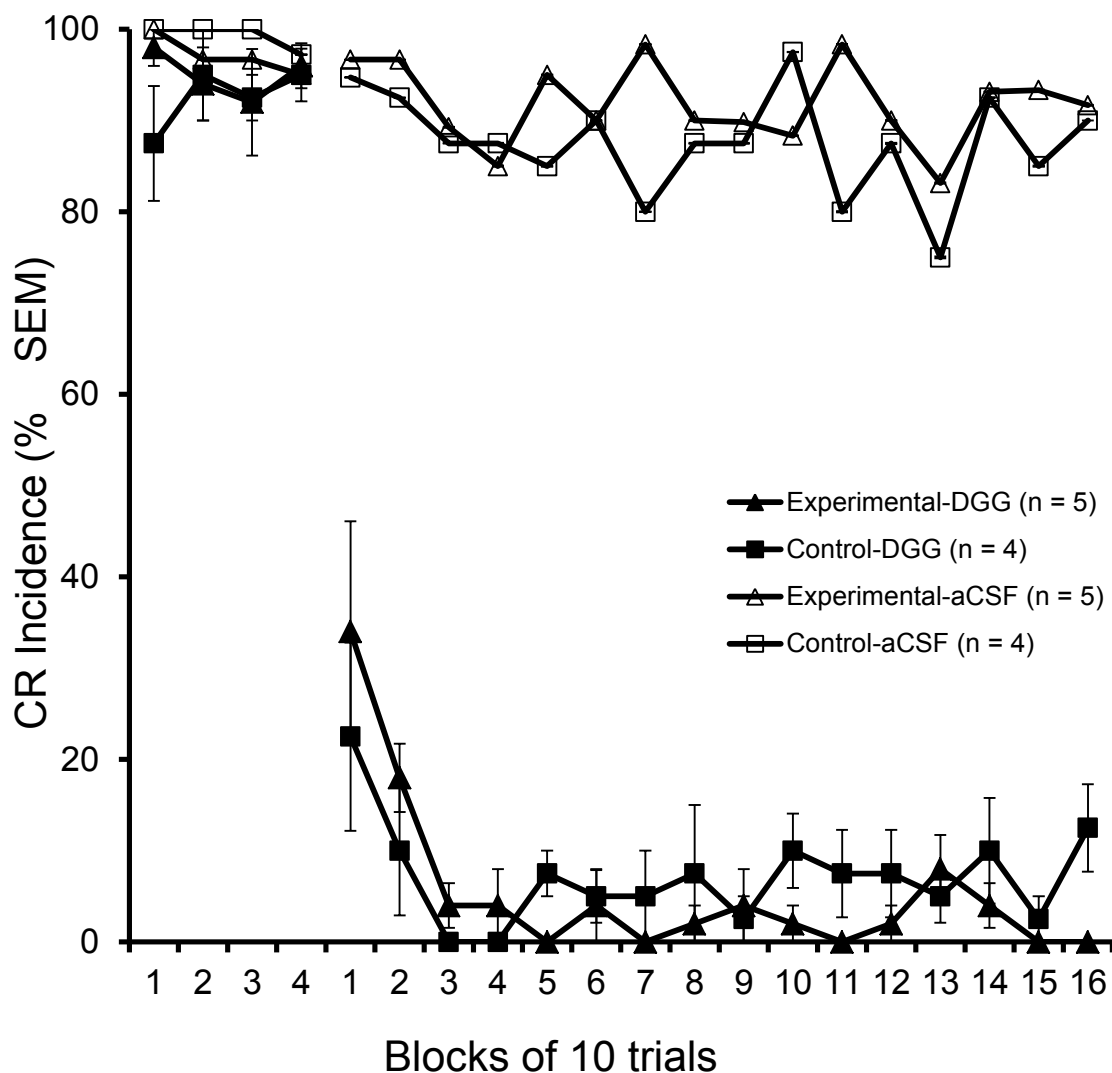

Figure 3. Group data for tone CS-evoked CR incidence (\pm SEM) following mapping DGG (n = 5) or vehicle (n = 4) injections in the IO. The dashed vertical line indicates the time of injection. The abscissa represents blocks of 10 trials which are numbered separately for the pre- and post-injection periods. DGG injections in both the experimental group (black triangles) and control group (black squares) rapidly abolished CRs and CR expression did not recover until the end of the experiment. Injections of vehicle had no effect on CR incidence.

no blinks to the vCS while the control rabbit had a high number of vCS-evoked CRs on Day 3. In the group data in Figure 5A, animals in the experimental group exhibited virtually no CRs during acquisition, while the control group showed a high rate of CR acquisition to the vCS. In the tone CS probe trials, tone-evoked CR expression was completely abolished (Figs. 4B, 5B), indicating a major DGG effect during the entire acquisition experiment. Conversely, control rabbits consistently exhibited normally timed, tone-evoked CRs (Figs. 4D, 5B). The consistent effect of DGG on vCS-related CR expression is shown in Figure 6A. Over the course of all three acquisition sessions, the frequency of blinks in the CS-US interval in this rabbit did not exceed the spontaneous eyeblink rate, and the small spontaneous blinks were inter-mixed with occasional slight eyelid movements (e.g., several of the last trials on day 3 in Fig. 6C). Control rabbits exhibited rapid CR acquisition culminating with an asymptotic CR performance by Day 3 (Fig. 4). Rabbits trained while being injected with DGG showed a significantly lower number of responses on all three days (e.g., Day 1: $F_1 = 22.5$, $p = 0.002$) compared to the control group's rapid rise to asymptotic performance.

3.4.3 Retention test

Following acquisition, a no-injection, 40-trial, vCS-alone retention test was performed. In this test, the experimental group exhibited a surprisingly high incidence of vCS-evoked CRs (35%), providing unequivocal evidence that learning occurred during the DGG phase of acquisition training (Fig. 5A). An individual example of CR performance in the retention test for a rabbit in the experimental group is shown in Figure 6D. This animal

exhibited a high level of well-timed CRs to the vCS throughout the retention test and it showed signs of extinction towards the end of the session. One of the five experimental rabbits was extremely sensitive to the vCS and for the acquisition training, we had to select the lowest vCS intensity available in our airpuff delivery system to prevent vCS-evoked URs. This rabbit failed to show high CR incidence in the retention test, but exhibited above-normal CR incidence during each day of post-acquisition training. While rabbits in the control group exhibited a higher mean level of CRs during retention, individual performances varied such that the two groups were not statistically different ($F_{1,7} = 4.38, p = 0.075$).

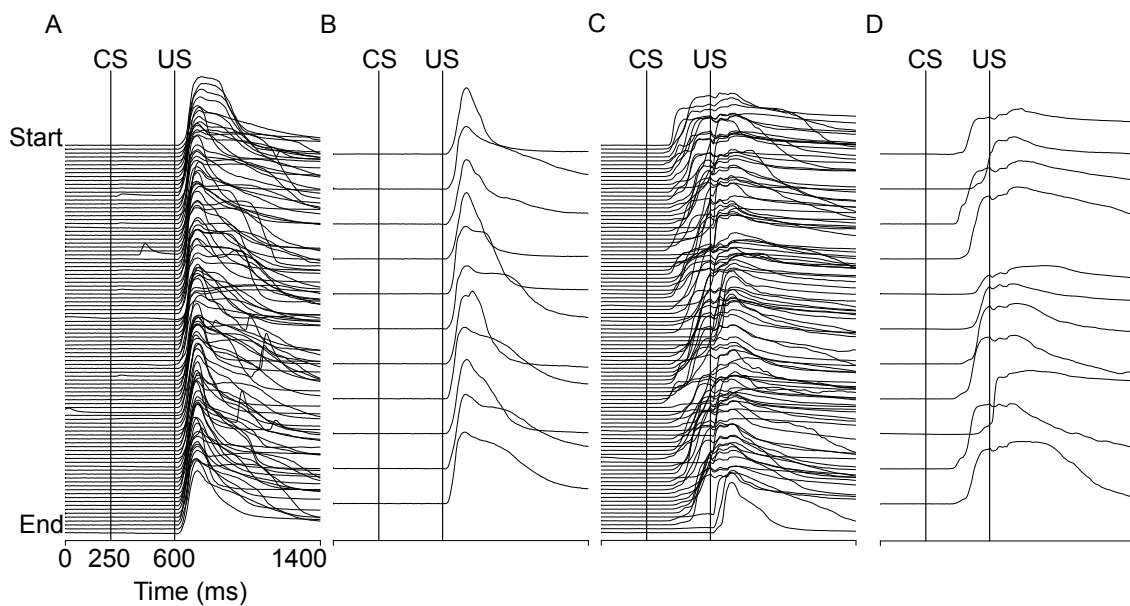

Figure 4. Individual examples of vibrissal and tone CS trials from Day 3 of acquisition with DGG or vehicle injections in the IO. (A) Example showing a 100-trial vibrissal CS (vCS) acquisition experiment following a DGG injection. The rabbit was exhibiting no CRs on this last day of acquisition. (B) The probe tone CS trials delivered to the rabbit during the same acquisition session as in (A). The DGG injection prevented expression of previously

learned CRs. (C) A stack plot of eyeblinks of a control animal that was injected with vehicle. At this stage of acquisition, the control rabbit expressed robust CRs. (D) Eyeblinks in the tone CS trials presented in the same session as in (C). In these trials, the control animal shows well-timed CRs to the previously learned tone CS.

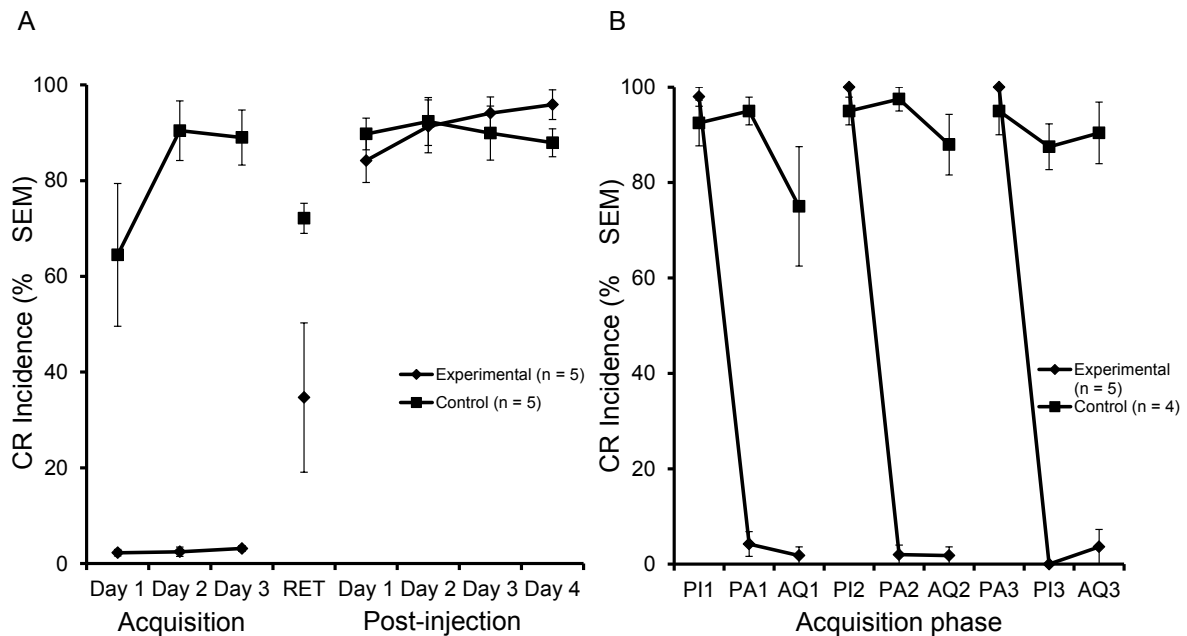

Figure 5. Group effects on vCS-evoked CR incidence (\pm SEM) during acquisition, retention test (RET) and post-acquisition training for the experimental group (diamonds, $n = 5$) and control group (squares, $n = 4$). (A) DGG injections suppressed expression of any vCS-evoked CRs during acquisition but did not block learning as shown by the presence of relatively high CR incidence in the retention test. The control group acquired CRs to the vCS quickly and CR expression reached asymptote by Day 2. Both groups showed asymptotic levels of CR incidence from the first day of the no-injection, post-acquisition training. (B) Tone CR incidence during the 3 days of acquisition. Both groups showed high levels of CRs during the pre-injection (PI) trials. DGG injections in the experimental group

blocked expression of tone-evoked CRs in both the pre-acquisition (PA) and acquisition (AQ) trials. Vehicle injections in the control group had no effect on expression of tone-evoked CRs.

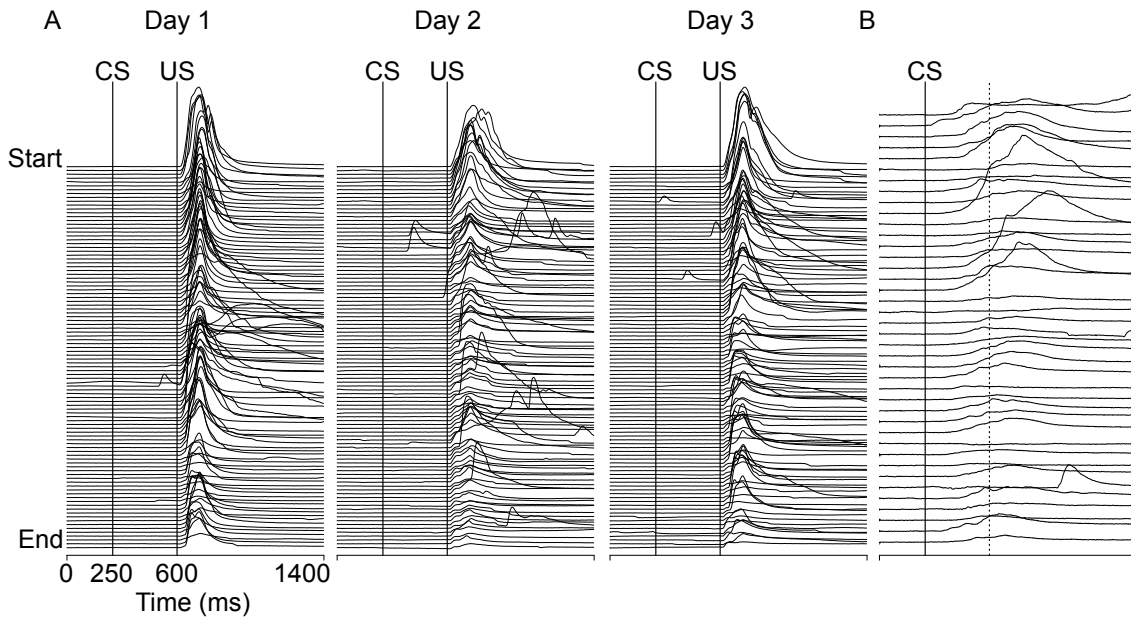

Figure 6. A complete printout of all eyeblinks generated by one of DGG-injected experimental rabbit during three days of vCS training and in the retention test. (A) With the exception of several spontaneous responses, DGG in this rabbit suppresses expression of CRs throughout the acquisition phase of the study. (B) In spite of showing no CRs during acquisition, the same animal exhibited well-formed vCS-evoked CRs in the vCS-alone retention test. Dashed vertical line shows where the onset of US would normally occur in a paired stimuli experiment.

3.4.4 Post-acquisition training

The retention test for both the experimental and control groups showed no deficits in learning the association or any lingering effects from the previous day's DGG injection. Consistent with learning having occurred during the DGG acquisition phase, the learning curve of the experimental group was indistinguishable from controls (Figure 5A) (group $F_{1,7} = 0.036$, $p = 0.85$ and group*day $F_{2,14} = 0.81$, $p = 0.46$).

3.5 Discussion

The present study tested whether interfering with IO US signals by blocking glutamate neurotransmission in the IO would affect CR acquisition to a vibrissal CS. As expected, microinjections of DGG prevented expression of CRs to both the vCS and to the previously learned tone CS (Figs. 3 & 5). Although blocking glutamate neurotransmission in the IO suppressed CRs to either CS modality during acquisition, rabbits exhibited CRs to the vCS in the retention test, when no drugs were injected and the IO thus operated normally. This shows rabbits were able to acquire CRs even though IO US signals to the cerebellum were either blocked or at least severely suppressed.

Prevailing concepts of eyeblink conditioning postulate that the IO provides the intermediate cerebellum with a teaching US signal which is required for CR acquisition and maintenance (Thompson, 1986; De Zeeuw and Yeo, 2005). In agreement with this notion, electrophysiological studies demonstrated that the dorsal accessory olive responds to the trigeminal US (Gellman et al., 1983; Weiss et al., 1993). Further confirmation of the IO-dependent cerebellar learning hypothesis required showing that blocking the IO US signals would prevent CR acquisition, and that it would also lead to extinction of previously learned CRs. Several experiments previously addressed these issues.

Seemingly supporting IO US signal-dependent cerebellar learning, IO lesions or temporary inactivation prevented CR acquisition (McCormick et al., 1985; Yeo et al., 1986; Welsh and Harvey, 1998). Results of studies blocking IO signals in trained animals were less conclusive. While Yeo et al. (1986) found that IO lesions abolished previously learned CRs immediately, McCormick et al. (1985) reported that IO lesions produce not immediate, but rather gradual, extinction-like CR suppression. Furthermore, it has been shown that reversibly blocking glutamate-mediated IO US signals in trained rabbits produced delayed, extinction-like CR suppression (Medina, Nores, and Mauk, 2002).

Our recent electrophysiological examination of blocking task-related IO signals in trained rabbits casted serious doubts on these early studies. Contrary to predictions of the cerebellar learning hypothesis, we found that blocking IO signals with microinjections of muscimol (GABA agonist), DGG or NBQX (fast glutamate receptor antagonists) invariably abolished CRs (Zbarska et al., 2007; 2008). Importantly, our single-unit recording of neuronal activity in deep cerebellar nuclei unveiled the neurophysiological mechanism of CR abolition. In agreement with early reports of tonic effects of IO lesions (Colin et al., 1980; Montarolo et al., 1982; Batini et al., 1985), we found that these treatments somewhat counter-intuitively suppressed the neuronal activity in cerebellar interposed nuclei. Since direct suppression of cerebellar nuclear activity with muscimol or lidocaine is known to block CR expression (Bracha et al., 1994; Welsh and Harvey, 1991), we concluded that the IO manipulation-induced suppression of cerebellar nuclear activity was a direct cause of CR abolition. These findings demonstrated that due to their side-effects (i.e. non-specific

suppression of cerebellar nuclear activity), IO lesions or blocking IO neurotransmission are invalid methods for testing the functional significance of IO signals in eyeblink conditioning.

It became clear that future investigations of the IO's contribution to eyeblink conditioning will require new approaches that not only block IO US signals, but also minimize possible effects on the tonic activity of cerebellar circuits (for review see Bracha et al., 2009). Toward this end, we started to develop combined injection protocols which would block IO task-related signals while maintaining near-normal cerebellar activity (Zbarska and Bracha, 2012; Zbarska et al., 2009). Results reported here represent the first step in our attempt to establish a baseline effect of blocking glutamate-mediated IO signals during CR acquisition, without compensating for associated shifts in cerebellar spontaneous activity. We hypothesized that rabbits trained in these conditions would not acquire CRs because DGG will render cerebellar circuits dysfunctional and/or because it will block IO US signals that are presumably required for learning. Surprisingly, we found that injections of DGG did not prevent CR acquisition. The simplest explanation for this finding is that glutamate-mediated IO US signals are not required for CR acquisition. This conclusion contradicts one of the major tenets of the cerebellar learning hypothesis in which IO US signals are pivotal for learning. Notably, this finding does not preclude cerebellar learning in general. While IO US signals might not be essential, other evidence suggests that the intermediate cerebellum indeed plays a role in CR acquisition (e.g. Bracha et al., 1998; Kellet et al., 2010). If so, the underlying mechanism would have to be remarkably robust to withstand IO DGG-induced shifts in the spontaneous activity of the cerebellar cortex and nuclei, and it would have to rely on mossy fibers for both the CS and US information.

If glutamate-mediated IO US signals are not required for CR acquisition, then why did IO lesions (McCormick et al., 1985; Yeo et al., 1986,) and inactivation with lidocaine (Welsh and Harvey, 1998), prevent learning in previous studies? The most likely explanation is that silencing the IO via lesioning or inactivation generates non-specific effects on cerebellar physiology that are more disruptive than selectively blocking IO glutamate. Specifically, it is known that neurons in the IO are spontaneously active, producing firing rate of 1-2 spikes per second (Lang, 2001). Inferior olivary lesions and inactivation both block completely not only IO task-related signals, but also spontaneous climbing fiber activity. Blocking IO glutamate is less intrusive because even though it blocks the IO's responses to sensory inputs, it reduces, but does not eliminate the IO's spontaneous firing (Lang, 2001). Thus, it is possible that in the present experiment DGG preserved residual IO spontaneous activity. The decrease in IO activity was sufficient to suppress IN activity, via tonic interactions, enough to prevent CR expression. However, it was not severe enough to shift the activity in cerebellar eyeblink-related areas beyond the physiological range required for learning.

Before rejecting the IO's role in CR acquisition, alternate interpretations should be considered. It is possible that DGG injections did not eliminate all IO US signals and that the residual US-evoked IO activity was sufficient to support CR acquisition. However, this scenario does not seem likely. The placement of injection sites was centered on the rostral part of the dorsal accessory olive, which is known to contain the representation of the contralateral eye region (Weiss et al., 1993). One of the advantages of our experimental design was that it involved functional tests of DGG injection effectiveness. This allowed us to reduce the

likelihood of an incomplete block of IO US signals by implementing several precautionary steps. Specifically, to assure drug infusion into locations relevant to the eyeblink, we selected only sites where small DGG injections abolished previously learned, tone CS-evoked CRs (Zbarska et al., 2007). Then, to assure a complete and lasting drug effect during training, we doubled the DGG dose required for CR abolition and we verified its effect on tone CS-evoked CRs before initiating each acquisition session. Then, throughout each acquisition session, we confirmed the lasting drug effect using recurring tone CS probe trials to verify the abolition of CR expression. All these precautions confirmed that DGG injections were administered into the eyeblink representation area of the IO and that the resulting block of glutamate neurotransmission was strong enough to suppress the IO and consequently the IN activity to an extent rendering rabbits incapable of generating both previously learned and newly acquired CRs. However, it should be noted that these functional tests are only indirect measures of the extent to which DGG blocked IO US signals. Thus, we can't exclude that CR expression is more vulnerable to DGG-induced shifts of tonic cerebellar activity. Furthermore, while in this functional state which disabled CR expression, we can't exclude that the cerebellum was still receiving residual IO US signals that were sufficient to support learning. Even though this seems unlikely, future electrophysiological experiments will be required to exclude or confirm this critical alternate interpretation.

Another possible contributing factor enabling rabbits to acquire CRs in the present study could be the CS modality. We utilized a weak vibrissal airpuff CS because it produces faster acquisition of cerebellum-dependent CRs than traditional CS modalities such as a tone (Carrel et al., 2012). An accelerated learning rate afforded us the capability to reduce the

number of DGG injections and thus reduce the likelihood of an injection failure adversely affecting the experiment. The relative downside of using the non-traditional vCS is that we can't exclude that learning different CS sensory modalities is differentially dependent on IO signals. Information about the CS, whether auditory or trigeminal, is sent to the lateral pontine nuclei and then on to the eyeblink-related areas of the cerebellum (Halverson and Freeman, 2010). However, the sensory trigeminal nuclei also have direct projections to the cerebellum (Van Ham and Yeo, 1992). These direct projections could perhaps contribute to the faster CR acquisition observed when using the vCS and also to the ability of animals to acquire CRs even while blocking IO inputs. This possibility could be easily tested by blocking IO glutamate during eyeblink conditioning to the tone CS.

An additional noteworthy finding was the one rabbit that did not learn during the acquisition protocol. Since the placement of his implant was not significantly better than in rabbits that learned and because the dose of DGG was not higher than other animals, it is not likely that this subject's failure to learn was related to better penetration of the IO with the drug. Also, a possible injury of the IO does not explain the lack of learning in this animal because it acquired CRs quickly during post-acquisition training. Since this animal was extremely sensitive to the vCS and as a consequence it was exposed to the lowest CS intensity among all of the subjects in this study, we presume that his failure to acquire under DGG was not related to the drug, but to the low intensity of CS.

The present study made two important contributions. First, it confirmed previous observations that, contrary to expectations of the cerebellar learning hypothesis, blocking glutamate neurotransmission in the IO abolishes previously learned CRs rather than inducing

their extinction. The second and more important finding is that blocking IO task-related signals either completely, or at least enough to suppress CR expression, did not prevent acquisition of CRs to the vCS. This finding illustrates a remarkable resiliency of the learning mechanisms operating in spite of the cerebellum being in an abnormal functional state. Notwithstanding the alternative interpretations, the most parsimonious, and admittedly the most provocative, interpretation of the current data is that glutamate-mediated IO signals are not needed for CR acquisition. This conclusion portends exciting implications for possible mechanisms of eyeblink-related cerebellar learning. Confirming or falsifying this proposition will require careful electrophysiological tests designed to determine whether utilized doses of DGG are indeed capable of blocking completely all IO US signals. The general validity of this conclusion will also require testing whether CR acquisition to other CS modalities is similarly insensitive to blocking task-related inferior olivary signals.

3.6 References

- Batini C, Billard JM, Daniel H (1985) Long term modification of cerebellar inhibition after inferior olive degeneration. *Exp Brain Res* 59:404-409.
- Bracha V, Irwin KB, Webster ML, Wunderlich DA, Stachowiak MK, Bloedel JR (1998) Microinjections of anisomycin into the intermediate cerebellum during learning affect the acquisition of classically conditioned responses in the rabbit. *Brain Res* 788:169-178.

- Bracha V, Webster ML, Winters NK, Irwin KB, Bloedel JR (1994) Effects of muscimol inactivation of the cerebellar interposed-dentate nuclear complex on the performance of the nictitating membrane response in the rabbit. *Exp Brain Res* 100:453-468.
- Bracha V, Zbarska S, Parker K, Carrel A, Zenitsky G, Bloedel JR (2009) The cerebellum and eye-blink conditioning: learning versus network performance hypotheses. *Neuroscience* 162:787-796.
- Carrel AJ, Zbarska S, Zenitsky GD, Bracha V (2012) A trigeminal conditioned stimulus yields fast acquisition of cerebellum-dependent conditioned eyeblinks. *Behav Brain Res* 226:189-196.
- Colin F, Manil J, Desclin, JC (1980) The olivocerebellar system. I. Delayed and slow inhibitory effects: an overlooked salient feature of cerebellar climbing fibers. *Brain Res* 187: 3-27.
- De Zeeuw CI, Yeo CH (2005) Time and tide in cerebellar memory formation. *Curr Opin Neurobiol* 15:667-674.
- Gellman R, Houk JC, Gibson AR (1983) Somatosensory properties of the inferior olive of the cat. *J Comp Neurol* 215:228-243.
- Halverson HE, Freeman JH (2010) Medial auditory thalamic input to the lateral pontine nuclei is necessary for auditory eyeblink conditioning. *Neurobiol Learn Mem* 93:92-98.

- Kellett DO, Fukunaga I, Chen-Kubota E, Dean P, Yeo CH (2010) Memory consolidation in the cerebellar cortex. *PLoS One* 5:e11737.
- Krupa DJ, Thompson JK, Thompson RF (1993) Localization of a memory trace in the mammalian brain. *Science* 260:989-991.
- Lang EJ (2001) Organization of olivocerebellar activity in the absence of excitatory glutamatergic input. *J Neurosci* 21:1663-1675.
- McCormick DA, Steinmetz JE, Thompson RF (1985) Lesions of the inferior olivary complex cause extinction of the classically conditioned eyeblink response. *Brain Res* 359:120-130.
- Medina JF, Nores WL, Mauk MD (2002) Inhibition of climbing fibres is a signal for the extinction of conditioned eyelid responses. *Nature* 416:330-333.
- Mintz M, Lavond DG, Zhang AA, Yun Y, Thompson RF (1994) Unilateral inferior olive NMDA lesion leads to unilateral deficit in acquisition and retention of eyelid classical conditioning. *Behav Neural Biol* 61:218-224.
- Montarolo PG, Palestini M, Strata P (1982) The inhibitory effect of the olivocerebellar input on the cerebellar Purkinje cells in the rat. *J Physiol* 332:187-202.
- Ryan SB, Detweiler KL, Holland KH, Hord MA, Bracha V (2006) A long-range, wide field-of-view infrared eyeblink detector. *J Neurosci Methods* 152:74-82.

- Thompson RF (1986) The neurobiology of learning and memory. *Science* 233:941-947.
- Van Ham JJ, Yeo CH (1992) Somatosensory Trigeminal Projections to the Inferior Olive, Cerebellum and other Precerebellar Nuclei in Rabbits. *Eur J Neurosci* 4:302-317.
- Weiss C, Disterhoft JF, Gibson AR, Houk JC (1993) Receptive fields of single cells from the face zone of the cat rostral dorsal accessory olive. *Brain Res* 605:207-213.
- Welsh JP, Harvey JA (1991) Pavlovian conditioning in the rabbit during inactivation of the interpositus nucleus. *J Physiol* 444:459-480.
- Welsh JP, Harvey JA (1998) Acute inactivation of the inferior olive blocks associative learning. *Eur J Neurosci* 10:3321-3332.
- Yeo CH, Hardiman MJ, Glickstein M (1986) Classical conditioning of the nictitating membrane response of the rabbit. IV. Lesions of the inferior olive. *Exp Brain Res* 63:81-92.
- Zbarska S, Bloedel JR, Bracha V (2008) Cerebellar dysfunction explains the extinction-like abolition of conditioned eyeblinks after NBQX injections in the inferior olive. *J Neurosci* 28:10-20.
- Zbarska S, Bracha V (2012) Assessing the role of inferior olivary sensory signaling in the expression of conditioned eyeblinks using a combined glutamate/GABAA receptor antagonist protocol. *J Neurophysiol* 107:273-282.

Zbarska S, Holland EA, Bloedel JR, Bracha V (2007) Inferior olivary inactivation abolishes conditioned eyeblinks: extinction or cerebellar malfunction? *Behav Brain Res* 178:128-138.

Zbarska S, Bloedel JR, Bracha V (2009) Compensating for the inferior olive inactivation-induced tonic cerebellar dysfunction: Conditioned eyeblinks and cerebellar nuclear neuronal activity. Society for Neuroscience, San Diego, CA.

**CHAPTER 4: EFFECTS OF BLOCKING GLUTAMATE
NEUROTRANSMISSION IN THE INFERIOR OLIVE ON EYEBLINK
CONDITIONING-RELATED INFERIOR OLIVARY SIGNALS – A
PILOT STUDY.**

A.J. Carrel^{8,9}, G.D. Zenitsky⁸, and V. Bracha⁸

4.1 Abstract

A popular version of the cerebellar learning hypothesis assumes that the IO provides the cerebellum with a US teaching signal that is required for CR acquisition. Our previous experiments (Chapter 3) seriously challenged this notion by showing that rabbits could acquire CRs when IO US sensory signals were presumably blocked by the glutamate antagonist DGG when applied to the IO. Concluding that IO US signals are indeed not required for eyeblink conditioning requires showing explicitly that IO DGG injections that abolish CRs also block IO US signals.

To examine this issue, trained rabbits were injected in the IO with the glutamate antagonist DGG and effects of this treatment on the incidence of IO signal-triggered Purkinje cell complex spikes were examined. In this pilot experiment, we found that CR-abolishing DGG injections blocked all complex spike activity in eyeblink-related Purkinje

⁸ Department of Biomedical Sciences, Iowa State University.

⁹ Primary researcher.

cells. This finding suggests that DGG suppressed both the task-related IO signals and the spontaneous activity of IO neurons. These data further support the notion that contrary to the central postulate of the cerebellar learning hypothesis, IO US signals are not required for CR acquisition.

4.2 Introduction

Axons from neurons in the IO are the only source of climbing fibers that synapse onto cerebellar Purkinje cells and cerebellar nuclei (Desclin, 1974). These climbing fibers contain a unique pattern of innervation in that Purkinje cells receive input from only one climbing fiber and the climbing fiber makes several synaptic contacts on the Purkinje cell dendrites as it ascends towards the distal ends of the dendrites. Climbing fiber activation produces a distinct burst of high-frequency spikes in Purkinje cells called the complex spike (Eccles et al., 1966).

The cerebellar learning hypothesis proposes that IO US signals, which are expressed in the cerebellar cortex as US-correlated complex spikes, are required for CR acquisition (Mostofi et al., 2010). Contrary to this popular belief, our acquisition studies in Chapter 3 show that even though microinjections of the glutamate antagonist γ -D-Glutamylglycine (DGG) in the IO block US signals, they did not block CR acquisition. Although rabbits did not express CRs during the acquisition sessions, we could not exclude that our DGG injections did not completely block IO task-related sensory signals and the residual signals were sufficient to support learning.

To measure directly how blocking IO glutamate affects IO signals, we initiated a preliminary study in which we measured the incidence of complex spikes in the cerebellar

cortex before and after DGG microinjections in the IO. The main objective of this study was to obtain preliminary data that could be used in future grant applications. Rabbits were implanted with an array of microelectrode guide tubes in lobule HVI of the cerebellar cortex, which contains the eyeblink representation (Yeo et al., 1985, Mostofi et al., 2010). We hypothesized that the amounts of DGG that were injected during our acquisition experiments (see Chapter 3 Methods) will completely suppress US-triggered complex spikes in eyeblink-related Purkinje cells. The preliminary data presented here are consistent with this prediction.

4.3 Methods

4.3.1 Subjects

Experiments were performed on two male New Zealand White Rabbits (Harlan; Indianapolis, IN) weighing 2.5–3.0 kg (3–4 months old at time of surgery). Rabbits were housed individually on a 12-hour light/dark cycle and provided food and water *ad libitum*. All experiments were performed in accordance with the National Institutes of Health's "Principles of Laboratory Animal Care" (publication No. 86-23, revised 1985), the American Physiological Society's "Guiding Principles in the Care and Use of Animals," and the protocol approved by Iowa State University's Animal Care and Use Committee.

4.3.2 Surgery

Surgical implantations were performed using aseptic techniques on naïve rabbits anesthetized with a mixture of ketamine (50 mg/kg), xylazine (6 mg/kg) and acepromazine (1.5 mg/kg). The head was secured in a stereotaxic apparatus with lambda positioned 1.5 mm ventral to bregma. After exposing the skull and affixing three stainless steel anchor

screws and a silver ground screw, a stainless steel injection guide tube (27-gauge thin-wall) was implanted stereotaxically targeting the dorsal aspects of the right IO ($((0.69x + 4.5) - x)$ rostral from lambda, x being the horizontal distance between bregma and lambda in mm; 1.0 mm lateral; and 23.4 mm ventral from lambda). An array of 3 guide tubes was also stereotaxically implanted targeting the medial aspect of cerebellar lobule HVI ($((0.69x + 5.3) - x)$ rostral from lambda in mm; 1.0 mm lateral; and 9.75 mm ventral from lambda). In order to protect the patency of the guide tubes, a 33-gauge stainless steel stylet was inserted each guide tube between experiments. The guide tubes, anchor screws, silver ground screw, a miniature ground connector and a small Delrin block designed to accommodate an airpuff delivery nozzle and eyeblink sensor were all secured in place with dental acrylic. All animals were treated with antibiotics for 5 days while recovering from surgery.

4.3.3 Training procedures

Prior to surgery, rabbits were adapted to a restraint box (Plas-Labs Inc., Lansing, MI) inside a sound-attenuating chamber for 30 min on two consecutive days. After recovery from surgery, rabbits were given one additional day of box adaptation. Box-adapted rabbits were conditioned using the delay classical conditioning paradigm until they reached $\geq 90\%$ conditioned responses (CRs) for 3 consecutive training days. The conditioned stimulus (CS) was a 450-ms, weak airpuff directed at rows B and C of the left mystacial vibrissae (vCS). The strength of the CS was individually calibrated for each rabbit to an intensity just below the threshold that elicited an alpha response (for a more detailed description, see Carrel et al., 2012). The CS was delivered using a Precision Pressure Regulator Type 10LR (Bellofram Corporation, Newell, WV). The vCS co-terminated with a 100-ms, 36-psi (at the source)

unconditioned stimulus (US) directed at the left cornea. The inter-stimulus interval was 350 ms and the intertrial interval varied pseudorandomly between 15-25 sec. Each training session consisted of 100 paired trials per day.

4.3.4 Injection procedures

Microinjections were delivered utilizing a 33-gauge stainless steel injection needle connected to a 10- μ l Hamilton syringe (Hamilton Company, Reno, NV) via transparent Tygon tubing. The Tygon tubing was initially filled with ultra-purified water, then a small air bubble was pulled into the injection needle, followed by the drug being drawn into the tubing. The movement of the bubble was used to monitor the volume of drug being injected relative to gradation marks located on the tubing. An AMPA/kainate and NMDA receptor antagonist, γ -D-Glutamylglycine (DGG, Tocris Bioscience, USA), was dissolved in artificial CSF (aCSF) and its pH was adjusted to 7.4 ± 0.1 . The injections were performed manually at a rate of 0.25 μ l/min.

In the first part of the study, IO functional mapping sessions were performed using injections of DGG (0.5 μ l, 100 nmol/ μ l) to ascertain the precise location and volume of DGG necessary to quickly abolish previously learned vCS-evoked CRs. The injection needle was inserted in the guide tube before commencing the experiment. Rabbits were given 40 pre-injection trials to ensure there were no effects on CR performance due to needle insertion. Following the drug injection, an additional 160 post-injection trials were presented to the rabbit. In the first mapping experiment, DGG was injected at a depth that paralleled the tip of the guide tube. Subsequent DGG injections were given every 20 trials until we observed a drug effect or a maximum of 2 μ l had been injected. If there was no notable drug effect on

CR incidence, the injection needle was advanced ventrally an additional 0.5 mm the following day and the mapping session was repeated. This daily advancement was performed until DGG injections completely abolished CRs or until the needle reached the base of the cranial cavity. The volumes required for maintenance of DGG abolition for the post-injection trials ranged from 0.5 μ l – 1.5 μ l.

4.3.5 Electrophysiology procedures

Recording of complex spike activity in the cerebellar cortex was performed using a stainless steel electrode (1.5-5 M Ω , Frederick Haer Company, Bowdoinham, ME) inserted into one of the three guide tubes targeting lobule HVI. Electrodes were advanced ventrally using a custom-made manipulator attached to the 3-guide tube array. The electrode was advanced until a Purkinje cell exhibiting a complex spike to the CS and/or US was isolated. At that point, paired vCS-US trials were presented to the rabbit. If the isolated unit was maintained through the pre-injection trials, DGG was injected in the IO and then paired trials and single-unit recording continued for the remainder of the experiment, which comprised the post-injection and recovery periods.

4.3.6 Data recording and analysis

Movements of the eyelids were recorded as described in Chapter 3. Single-unit signals from electrodes were pre-amplified with a FET-based preamplifier and then further amplified with a differential amplifier system (model 12 Neurodata System; Grass-Telefactor, WestWarwick, RI). The amplified and bandpass-filtered (300 Hz–3 kHz) signal was digitized (25 kHz/channel) using a custom data acquisition system, and was displayed and stored in 1400 ms epochs corresponding to individual trials. Unit discrimination was

performed off-line using threshold detection followed by a cluster analysis of scatter plots of time and amplitude distances between the peak and valley of individual action potential waveforms. The discriminated data were processed using custom software. Raster and peri-event histograms were constructed for each unit. The criterion for identifying the recovery period was the behavioral reappearance of CRs. In each histogram, the baseline firing rate (250 ms before CS onset) and the timing of significant excitatory and inhibitory changes were computed. Cell responses were considered significant if modulation of the firing rate from the CS onset until the end of the trial exceeded the mean baseline tolerance limit for two consecutive 20 ms bins. Tolerance limits were computed to capture 95% of the baseline distribution with a probability of 0.95.

4.3.7 Histology

After all experiments were concluded, rabbits were deeply anesthetized with a cocktail of ketamine (100 mg/kg), xylazine (12 mg/kg), and acepromazine (3 mg/kg). Injection sites were marked by injecting 0.75 μ l of tissue-marking dye. Recording sites were marked by electrolytical deposition of iron from recording electrodes. Rabbits were transcardially perfused with 1 L of phosphate-buffered saline followed by 1 L of tissue fixative (10% neutral-buffered formalin) and 1 L of 10% potassium ferrocyanide in 10% formalin. The potassium ferrocyanide allows electrodes to be marked by passing 10 μ A anodal DC current through the electrode for 20 seconds. Excised brains were stored in a solution of 30% sucrose and 10% formalin. Brains were sectioned coronally in 50- μ m slices on a freezing microtome. Subsequently, sections were mounted on gelatin-coated slides, dried, and stained with ferrocyanide hydrochloride and neutral red. Injection site locations

were identified using bright light microscopy and plotted on standardized sections of the rabbit cerebellum and medulla.

4.4 Results

Purkinje cell complex spikes (Fig. 1) were recorded in two rabbits. Although we were able to obtain recordings of Purkinje cell complex spikes in both animals, we isolated stimulus-induced complex spikes only in one rabbit.

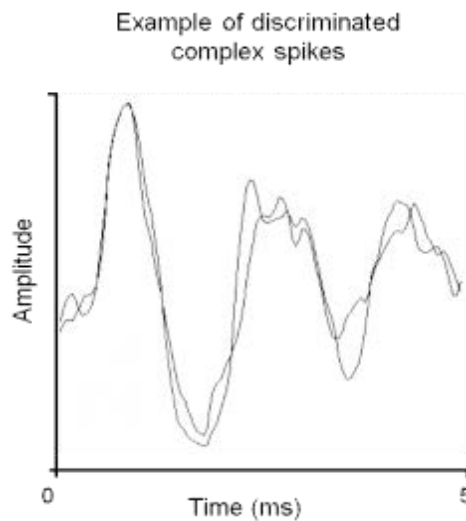

Figure 1. An individual example of complex spike wave shapes recorded from a Purkinje cell in cerebellar lobulus HVI.

Figure 2 illustrates the distribution of complex spikes in a Purkinje cell that was successfully held throughout a 265-trial experiment. Typical for the IO firing rates, the pre-injection frequency of complex spikes was between 2-3 Hz. On the background of this firing rate, the cell exhibited stimulus-related excitatory modulation. In this particular case, this Purkinje cell responded with complex spikes to both the CS and US. In fact, most recorded cells

responded to both the CS and US, which were of the same sensory modality. Following the DGG administration, CRs were abolished as manifested by the shift of eyeblink onsets past the onset of the US. In parallel to this behavioral effect, the complex spike firing almost completely ceased. This is an interesting finding because previous experiments show that injecting another glutamate antagonist (NBQX) in the IO reduces but does not abolish complex spike firing (Lang 2001; 2002). This effect lasted about 35 trials after which complex spikes began to recover. In the case illustrated in Figure 2, responses to the vCS recovered first and this was followed by the spontaneous activity and eventually US response recovery. The recovery of complex spike activity preceded the restoration of behavioral CRs.

4.5 Discussion

This pilot study tested the effects of blocking IO glutamate neurotransmission with DGG on the conditioning-related complex spike activity of Purkinje cells. Our experiments demonstrated the suitability of our recording technique for isolating conditioning-related complex spikes and for maintaining the isolation of recorded cells for the duration of the drug injection experiment. Even though several recorded cells by no means represent the whole population of eyeblink-related cells, the acquired data demonstrated that in principle, IO DGG could completely suppress IO US signals – a result which, when combined with the outcome of acquisition experiments described in Chapter 3, reinforces the notion that IO US signals are not essential for eyeblink conditioning. This conclusion will require further experimentation to accumulate a more representative sample of eyeblink-related Purkinje cells. Also, these future experiments will have to focus on assessing the duration of the DGG

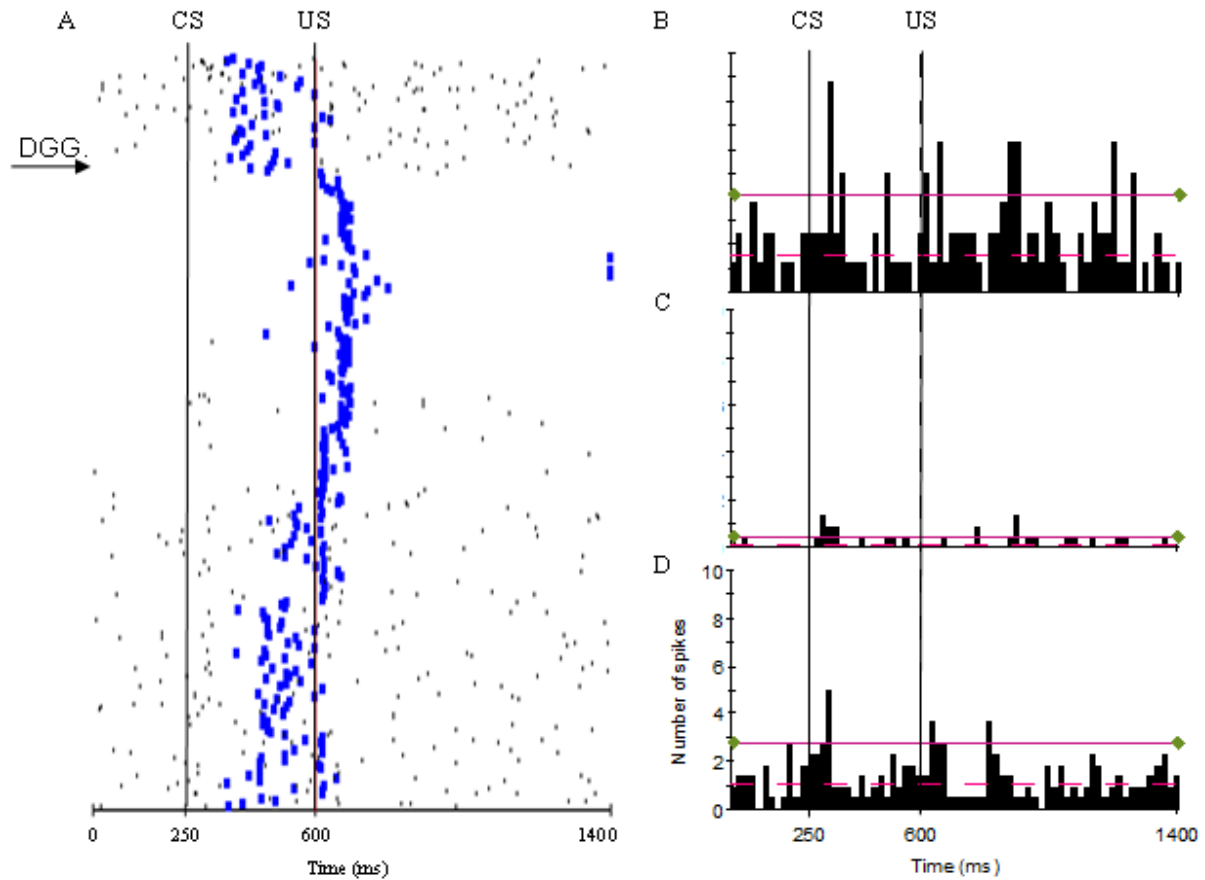

Figure 2. An example of the effects of DGG injections in the IO on complex spike activity in a cerebellar Purkinje cell. The experiment consisted of 265 trials. (A) Raster plot of complex spikes in a Purkinje cell. The experiment starts at the top with each row representing one trial. The blue square in each trial indicates onset of the eyeblink response for that particular trial. Each black dot designates the occurrence of a recorded complex spike. The cell responded with complex spikes following both the CS and US during pre-injection trials. Shortly after the DGG injection, CRs and complex spike activity were suppressed. Complex spike responses to the vCS recovered first and this was followed by gradual recovery of spontaneous activity, responses to the US and eventually also behavioral CRs. (B–D), Peri-

stimulus histograms of the same Purkinje cell neuron constructed for 30 trials before the injection (B), for 115 post-injection trials when behavioral CRs were abolished (C), and the last 110 trials of recovery (D). Bin width for histograms in B–D is 20 ms. CS, conditioned stimulus onset; US, unconditioned stimulus onset.

effects on PC complex spikes using doses of DGG that exceed those used in experiments described in the Chapter 3. Ultimately, results of these future electrophysiological experiments will be essential for rejecting the role of IO in eyeblink conditioning or for designing more adequate tests of the cerebellar learning hypothesis.

4.6 References

- Carrel AJ, Zbarska S, Zenitsky GD, Bracha V (2012) A trigeminal conditioned stimulus yields fast acquisition of cerebellum-dependent conditioned eyeblinks. *Behav Brain Res* 226:189-196.
- Desclin JC (1974) Histological evidence supporting the inferior olive as the major source of cerebellar climbing fibers in the rat. *Brain Res* 77:365-384.
- Eccles JC, Llinas R, Sasaki K (1966) The excitatory synaptic action of climbing fibres on the purinje cells of the cerebellum. *J Physiol* 182:268-296.
- Lang EJ (2001) Organization of olivocerebellar activity in the absence of excitatory glutamatergic input. *J Neurosci* 21:1663-1675.

Lang EJ (2002) GABAergic and glutamatergic modulation of spontaneous and motor-cortex-evoked complex spike activity. *J Neurophysiol* 87:1993-2008.

Mostofi A, Holtzman T, Grout AS, Yeo CH, Edgley SA (2010) Electrophysiological localization of eyeblink-related microzones in rabbit cerebellar cortex. *J Neurosci* 30:8920-8934.

Yeo CH, Hardiman MJ, Glickstein M (1985) Classical conditioning of the nictitating membrane response of the rabbit. III. Connections of cerebellar lobule HVI. *Exp Brain Res* 60:114-126.

CHAPTER 5: THE CEREBELLUM AND EYEBLINK CONDITIONING: LEARNING VERSUS NETWORK PERFORMANCE HYPOTHESES

A paper published in the journal “*Neuroscience*”¹⁰

V. Bracha^{11,12}, S. Zbarska¹¹, K. Parker¹¹, A. Carrel¹¹, and J. R. Bloedel¹¹

5.1 Abstract

Classical conditioning of the eyeblink reflex is a form of motor learning that is uniquely dependent on the cerebellum. The cerebellar learning hypothesis proposes that plasticity subserving eyeblink conditioning occurs in the cerebellum. The major evidence for this hypothesis originated from studies based on the telecommunications network metaphor of eyeblink circuits. These experiments inactivated parts of cerebellum-related networks during the acquisition and expression of classically conditioned eyeblinks in order to determine sites at which the plasticity occurred. However, recent evidence revealed that these manipulations could be explained by a network performance hypothesis which attributes learning deficits to a non-specific tonic dysfunction of eyeblink networks. Since eyeblink conditioning is mediated by a spontaneously active, recurrent neuronal network with strong tonic interactions, differentiating between the cerebellar learning hypothesis and the network performance hypothesis represents a major experimental challenge. A possible

¹⁰ Reprinted with permission of “*Neuroscience*”, 2009.

¹¹ Department of Biomedical Sciences, Iowa State University.

¹² Primary researcher and corresponding author.

solution to this problem is offered by several promising new approaches that minimize the effects of experimental interventions on spontaneous neuronal activity. Results from these studies indicate that plastic changes underlying eyeblink conditioning are distributed across several cerebellar and extra-cerebellar regions. Specific input interactions that induce these plastic changes as well as their cellular mechanisms remain unresolved.

5.2 The cerebellar learning hypothesis and classical conditioning of eyeblink responses

The classically conditioned eyeblink or nictitating membrane reflex is a unique type of associative learning in which the cerebellum plays a major role (Thompson, 1986, for review). In the delay conditioning paradigm, the conditioned stimulus (CS), a stimulus that normally does not evoke the reflex, is paired over successive trials and at a specific interval with an ensuing unconditioned stimulus (US), which is capable of eliciting the unconditioned response (UR) before the conditioning is initiated. In each trial the CS and US co-terminate (**Fig. 1**). As conditioning continues, a new eyeblink response, the conditioned response (CR), gradually develops in the interstimulus interval, and the peak of this response becomes progressively time-locked to the onset of the US. In addition, once acquired, the CR can be evoked by applying the CS alone.

In the early eighties of the last century, a very exciting observation was reported implicating the cerebellum in this type of learned behavior. Lesioning a specific region of the cerebellar nuclei disrupted the performance of the classically conditioned eyeblink reflex in the rabbit (Clark et al., 1984; Yeo et al., 1985). Subsequently, several reports were published demonstrating that the modulation of neurons in the critical regions of the

cerebellar cortex and nuclei is associated with the CS, US and CR (Berthier and Moore, 1986; Berthier and Moore, 1990).

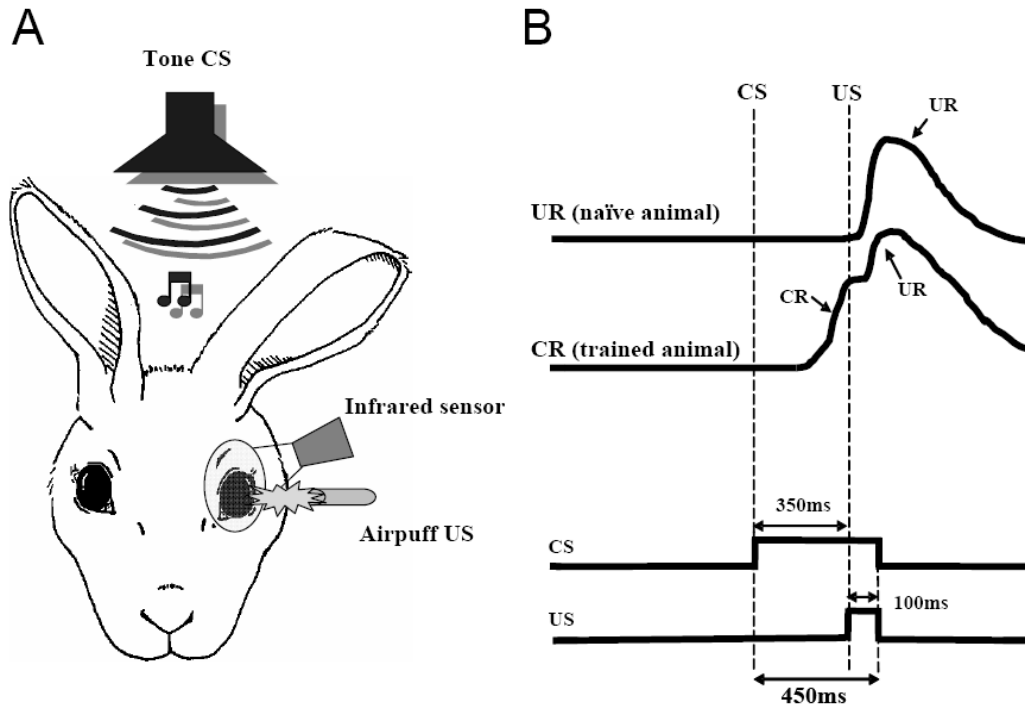

Figure 1. Schematic of the eyeblink conditioning paradigm. A: rabbits are presented with a paired tone conditioned stimulus (CS) and airpuff unconditioned stimulus (US). Evoked eyeblinks are recorded with an infrared sensor. B: idealized eyeblink records in naïve and trained animals and the pulse diagram denoting the timing of stimuli. In the delay classical conditioning paradigm, the onset of the CS precedes the onset of the US and the stimuli co-terminate. Naïve animals don't respond to the CS, but the US evokes reliably the hard-wired trigeminal unconditioned blink (UR, top eyeblink trace). Over time, rabbits associate the CS with the US, and they learn to blink in anticipation of the upcoming aversive US. These

associatively learned responses are called conditioned responses (CR, the second trace from the top).

In addition, substantial cerebellar involvement in this type of learning has been shown in other species (e.g. Skelton, 1988; Chen et al., 1996; Voneida et al., 1990), including humans (Lye et al., 1988; Solomon et al., 1989). Since these seminal observations, temporary and permanent lesion experiments have implicated the cerebellum in multiple processes underlying the classical conditioning of this reflex system, including acquisition, retention and consolidation (Bracha and Bloedel, 1996; Christian and Thompson, 2003; De Zeeuw and Yeo, 2005, for review). Finally, this dependence was found to extend to other types of conditioned reflexes. Manipulations of the cerebellar circuitry or permanent lesions in cerebellar patients disrupted instrumentally conditioned eyelid closure (Bracha et al., 2001) and classically conditioned withdrawal reflexes in the extremities of cats (Kolb et al., 1997; Bracha et al., 1999) as well as humans (Timmann et al., 2000). Because of the extensive data from several laboratories dealing with the classically conditioned eyeblink reflex in the rabbit, our review will focus on data acquired from this species.

It is generally agreed that eyeblink conditioning in the delay paradigm is controlled by a combination of brainstem eyeblink reflex circuits and the intermediate cerebellar network, which is super-imposed over the UR system (**Fig. 2**). It has been proposed that the ipsilateral cerebellar interposed nuclei (IN) and the cerebellar cortex are essential and perhaps sufficient sites of plastic changes for generating the cerebellar CR motor command. This theoretical position, the cerebellar learning hypothesis, has been extensively reviewed

(Thompson, 1986; Christian and Thompson, 2003; Ohyama et al., 2002; Attwell et al., 2002; Bracha and Bloedel, 1996), and therefore, it will only be briefly outlined here. The primary tenet of this hypothesis is derived from original concepts posited by Albus (1971) and Marr (1969), who deduced testable predictions based on the cerebellum's unique anatomical structure and synaptic organization. It is assumed that information about the CS and US arrives to the cerebellum via two distinct routes. The CS is conveyed through mossy fibers originating in pontine nuclei, whereas the US is coded in the discharge of climbing fibers originating in the inferior olive (IO). Information from the mossy and climbing fibers eventually converges on cortical Purkinje cells and cerebellar nuclear neurons. It is presumed that the hetero-synaptic interaction at the points of convergence triggers local cellular plastic processes resulting in the changed responsiveness of Purkinje and/or nuclear cells. These plastic changes cause the network to respond to the CS mossy fiber signal by issuing a cerebellar nuclear "motor command" that triggers the CR.

Despite almost three decades of research examining the cerebellum's contribution to the acquisition, retention, and expression of the classically conditioned eyeblink reflex, a consensus regarding how this structure plays its important role in this behavior has not been reached. For example, in spite of numerous optimistic claims, specific contributions of the cerebellar cortex, cerebellar nuclei and extra-cerebellar substrates to plasticity that underlies learning are not known. This fundamental issue remains unresolved, mostly because of the lack of tools needed to interfere with learning without affecting both the local and global properties intrinsic to underlying circuits.

In this review we will first examine the conceptual underpinnings of experiments that tested the cerebellar learning hypothesis using local inactivation or manipulations of neurotransmitter signaling. We will outline the telecommunications network metaphor of eyeblink circuits, and we will show that some of the findings from studies that were designed based on this metaphor seem to disprove the cerebellar learning hypothesis or at the very least challenge some of its basic tenets. Then we will demonstrate that traditional cerebellar manipulations affect the spontaneous activity of neurons at the site of intervention and downstream from it, and that tonic interactions associated with this change can radically alter the functional state of the entire network. The tonic interactions in cerebellar systems have been largely overlooked in most discussions of the cerebellar learning hypothesis. We will argue that some of the pivotal observations that were declared to support this hypothesis can be ascribed to the effects that experimental manipulations had on the tonic activity of cerebellar circuitry and/or to methodological aspects of the experiments on which this view is based. We will present promising new data further supporting these arguments, and lastly, we will discuss approaches that could be used to address the function of eyeblink conditioning circuits more effectively.

5.3 The telecommunications network metaphor of eyeblink circuits

In most discussions of the neural substrates for the classically conditioned eyeblink reflex, it is often implicitly assumed that cerebellum-related eyeblink conditioning circuits (**Fig. 2**) operate as a telecommunications network. Telecommunications networks consist of links and nodes arranged so that messages may be passed from one part of the network to another over multiple links and through various nodes. To employ the metaphor, eyeblink

circuits consist of nodes (nuclei) and links (inter-connecting axons). Nodes in eyeblink conditioning circuits, individual nuclei or parts of the cerebellar cortex, are viewed as input-output processing units that transform input messages into output signals. Importantly, properties of this signal transformation can change during learning. Based on this metaphor, experimental interventions in eyeblink circuits, such as local inactivation, are viewed as means for disrupting local information processing and for depriving the rest of the circuit of locally generated or transmitted task-specific signals. However, this concept neglects the fact that nodes in eyeblink networks also exchange a continuous stream of spontaneous activity that shapes the functional state of the network. In our view, this omission has led to several surprising and misleading conclusions.

The telecommunications network metaphor can be implicated in several of the early inactivation studies. For example, Krupa et al. (1993) proposed that systematically inactivating individual nodes in the network during training sessions could be used to find places where learning-induced plasticity occurs. They speculated that successful CR acquisition during inactivation of a particular node would signify that plastic changes develop not at this node, but at some other up-stream parts of the network. On the other hand, failure of CR acquisition would mean that learning occurred either at the manipulated node or at some of its down-stream efferent targets. With this logical reasoning one could methodically examine individual nodes until all potential sites of learning were found. Over time, it has been shown that blocking glutamate neurotransmission in the cerebellar cortex (Attwell et al., 2001) or inactivating cerebellar nuclei (Krupa et al., 1993; Hardiman et al., 1996) during learning prevents CR acquisition. In contrast, inactivating a major intermediate

cerebellar efferent target, the red nucleus, had no effect on learning (Clark and Lavond, 1993; Krupa et al., 1993). These findings suggested that a significant site of plasticity related to CR acquisition is contained in the ipsilateral cerebellum.

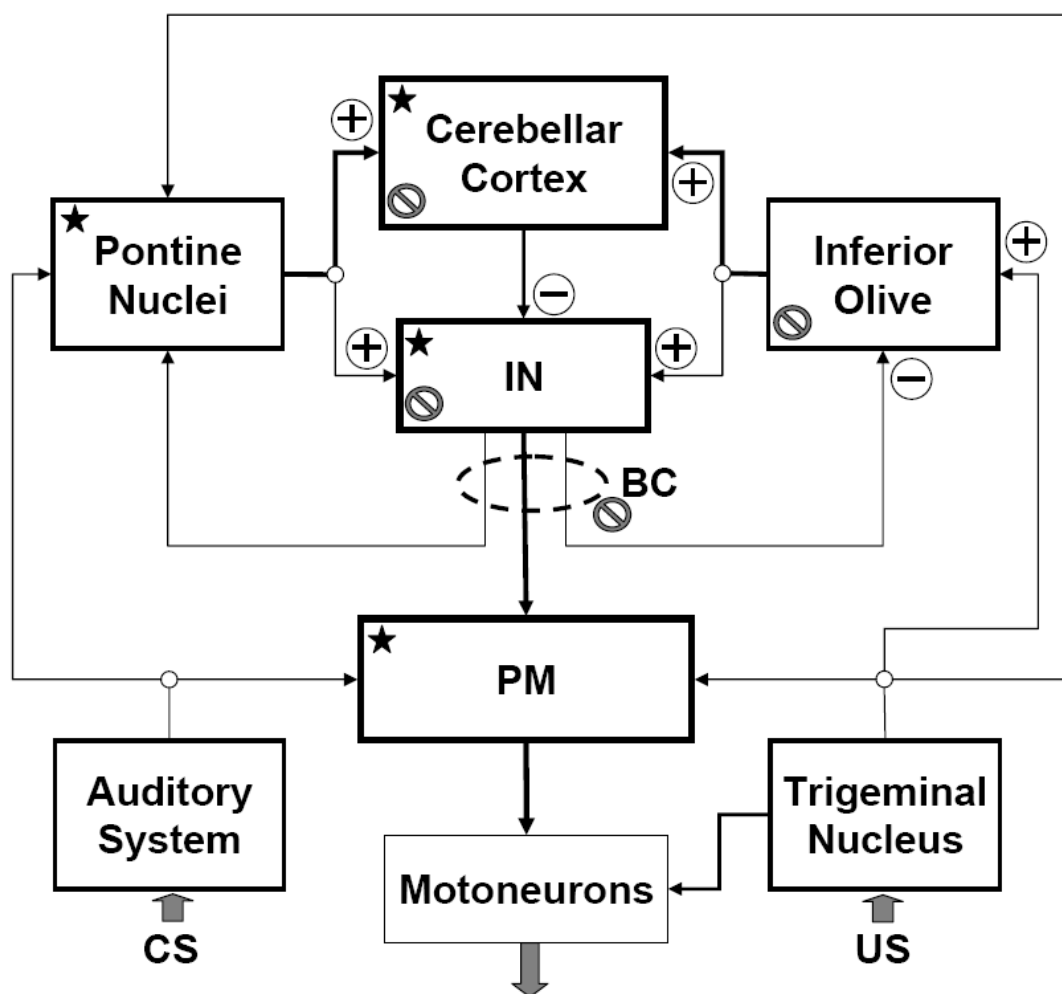

Figure 2. A conceptual block diagram of the cerebellum-related circuitry involved in acquisition and expression of classically conditioned eyeblinks in the rabbit. This diagram is a highly simplified representation of relevant structures and connectivity. Information

regarding the conditioned stimulus (CS) and unconditioned stimulus (US) information enters the network via auditory and sensory trigeminal systems. These inputs are supplied in parallel to the serially connected pontine nuclei, cerebellar cortex, cerebellar interposed nuclei (IN) and brainstem nuclei contributing to projections to eyeblink premotoneurons and supplying motor commands to them. Since all these sites (labeled with a star) receive CS and US information, they should be considered as putative sites of learning. Output of eyeblink premotoneurons supplies motor commands to eyeblink motoneurons. Backslashed circles denote nodes at which inactivation during training disrupts CR acquisition. Boxes with bold borders represent structures among which are in our view distributed plastic changes underlying eyeblink conditioning. BC – brachium conjunctivum; PM – nuclei containing eyeblink premotoneurons that include the red nucleus. The plus symbols mark excitatory glutamatergic inputs and minus signs label inhibitory GABAergic inputs.

However, this conclusion was strongly contradicted by our recent discovery that a carefully placed, more extensive inactivation of the brachium conjunctivum (outgoing axons of deep cerebellar nuclei, BC) actually *prevented* CR acquisition (Nilaweera et al., 2006). Using the logic derived from the metaphor, this surprising finding leads to an important inference: the learning essential for CR acquisition occurs most likely outside of the cerebellum, in extra-rubral cerebellar efferent targets! Before accepting this unexpected scenario, the possible role of cerebellar feedback circuits has to be considered.

Besides projections to pre-motoneuronal parts of eyeblink circuits, the BC contains axons projecting to cerebellar afferent sources in the IO and in the pontine nuclei and thus

participates in cerebellar feedback loops (**Fig. 2**). It is known that inactivating the IN does not prevent the pontine nuclei from transmitting CS signals (Cartford et al., 1997).

Therefore, inactivating the BC should not affect learning via its effect on CS signals from the pontine nuclei. Perhaps more important are the implications derived from the cerebello-olivary-cerebellar feedback loop. The cerebellar learning hypothesis assumes that the IO supplies the cerebellum with a learning-inducing US signal (error signal) and that the inhibitory projection to the IO from the cerebellar nuclei suppresses this signal when learning is near completion (e.g. Medina et al., 2002). If so, then inactivating the BC would disinhibit the IO, thereby preventing the suppression of US signals. This condition, however, should not prevent learning (Kim et al., 1998). Consequently, it is unlikely that the effects of BC inactivation on CR acquisition were related to changes in transmission of US signals by the IO. At a minimum, we can conclude that employing all the assumptions underlying the telecommunications network metaphor, together with data from our recent BC inactivation studies, implicate extra-cerebellar sites as additional structures subserving eyeblink conditioning.

A second unexpected conclusion emerged from studies that inactivated the IO during CR expression. As reviewed above, the cerebellar learning hypothesis postulates that cerebellar plasticity is induced by inferior olivary US error signals that enter the IO via glutamatergic projections from the trigeminal nuclei. Correspondingly, lesioning or inactivating the IO prevents CR acquisition (McCormick et al., 1985; Welsh and Harvey, 1998). Given the assumption that IO error signals are required for the maintenance of cerebellar plasticity, the cerebellar learning hypothesis predicts that blocking US responses in

the IO should lead to the gradual suppression of CRs – an “unlearning” of CRs analogous to CR extinction training in which the CS is repeatedly presented without the US (McCormick et al., 1985). The seemingly ultimate support for this concept came from Medina et al. (2002), who reported that blocking glutamate neurotransmission in the IO indeed produces the predicted extinction-like suppression of CRs. However, in our investigation of neurophysiological mechanisms of this phenomenon we found that the gradual suppression of CRs following the block of glutamate receptors in the IO is related to the gradual diffusion of the drug and not to unlearning (Zbarska et al., 2007; Zbarska et al., 2008). Moreover, we determined that precise injections of glutamate antagonists in the IO suppress CRs immediately. These behavioral results are clearly inconsistent with the cerebellar learning hypothesis.

The above findings, when viewed through the lens of the telecommunications network metaphor, contradict the cerebellar learning hypothesis. In the following sections we will argue that, before these contradictions can be considered as solid evidence favoring an alternative view incorporating extra-cerebellar sites of plasticity, a major flaw inherent in this metaphor needs to be exposed: the metaphor ignores the fact that experimental manipulations of cerebellar circuitry at the nodes of the eyeblink conditioning network generate coupled modifications of spontaneous activity capable of altering the functional state both within and beyond the targeted node, potentially cascading throughout the network. The inclusion of these tonic interactions in models of eyeblink circuits offers an alternate interpretation of the available experimental data.

5.4 Tonic interactions in cerebellar circuits

A fundamental feature of cerebellum-related eyeblink conditioning circuits is their spontaneous activity that can be observed in the absence of overt stimuli or movements. The spontaneous activity of individual neurons is a collective product of the intrinsic ability of some neurons (e.g. Purkinje cells, IO and IN neurons) to self-generate action potentials and of the drive from excitatory, inhibitory and modulatory synaptic inputs (Hausser et al., 2004). Spontaneous firing rates differ across individual nodes of the network. For example, the typical spontaneous firing rates of Purkinje cells, IN neurons and IO neurons are about 50 Hz, 10-40 Hz and 1-2 Hz, respectively. The spontaneous activity of individual neurons is propagated through the network affecting cells in other nuclei, and these effects are further sculpted by a number of excitatory and inhibitory recurrent loops. These dynamic, non-linear processes determine the self-regulating functional state of the network.

The importance of tonic activity in cerebellar circuits to the learning and execution of a specific motor behavior should not be a surprise. Several experimental studies over decades of research demonstrated that lesions within the cerebellum or its afferent or efferent systems produce significant tonic effects throughout the motor system, including modifications of a variety of spinal reflexes (for reviews see Dow and Moruzzi, 1958; MacKay and Murphy, 1979; Bloedel and Bracha, 1995). This is particularly clear when manipulating the olivo-cerebellar projection. The early experiments of Carrea et al. (1947) demonstrated that the effects of IO lesions on behavior are so profound that they actually mimic the effects of ablating major portions of the cerebellum itself. Later studies revealed that IO lesions and IO cooling have profound effects on the spontaneous activity of Purkinje

cells. Considering the very low firing rate of IO neurons, it was surprising that removing the IO excitatory input to Purkinje cells led to a high, long lasting increase of their spontaneous discharge (e.g., Montarolo et al., 1982). Central to the arguments we will present, this tonic effect emerging from IO inactivation affected the spontaneous firing rate of cells at downstream sites. Since Purkinje cells are GABA-ergic, their sustained high activity was shown to suppress activity in their target cerebellar nuclear neurons (Batini et al., 1985). In turn, the decreased firing of nuclear neurons suppressed activity in the red nucleus (Billard et al., 1988), which is the main target of excitatory IN projections. In summary, these studies uncovered two important principles:

a) spontaneous activity in cerebellar network nodes can regulate tonic activity in their efferent targets;

b) suppressing spontaneous activity in one node can trigger related tonic changes capable of spreading through large portions of the network, negatively impacting its general functional state.

How relevant are these principles to eyeblink conditioning research?

5.5 Tonic cerebellar interactions in classically conditioned rabbits

Although speculations had been made in a number of studies regarding tonic phenomena and their importance (e.g. Bracha and Bloedel, 1996; Welsh and Harvey, 1998; Attwell et al., 2001), their experimental demonstration in the rabbit eyeblink conditioning model was reported only recently. Characterizing tonic interactions in cerebellar circuits requires combining local circuit manipulations with recording of neuronal activity. For that purpose, we developed a unique, microwire-based, multi-channel recording system that is

well suited for long-term isolation of single units. The long-term stability of unitary recording is paramount for experiments that require monitoring cellular activity for at least 1-2 hours in animals with a freely moving head. In our initial studies, we focused on analyzing electrophysiological consequences of neurotransmitter manipulations in the IO and IN. Results of these experiments offer illuminating insights into the mechanisms through which cerebellar manipulations affect eyeblink conditioning.

As explained in previous sections, demonstrating that US signals from the IO are required for the maintenance of CRs constitutes a pivotal test of the cerebellar learning hypothesis. In a frequently cited study, Medina et al. (2002) proposed that this prediction could be tested by blocking trigeminal projections to the IO by infusing the IO of trained rabbits with a fast glutamate receptor blocker, NBQX. They reported that NBQX indeed produced an extinction-like, gradual suppression of CRs.

To investigate the neurophysiological mechanisms of this process, we injected NBQX in the IO of trained rabbits while simultaneously recording single-unit activity of IN neurons (Zbarska et al., 2008). Based on the prediction of Medina et al., which invokes the telecommunications network metaphor, one would expect NBQX to gradually “extinguish” CRs with a correlated gradual decrease of the CR-related modulation of neuronal activity in the IN. On the other hand, if NBQX decreases the spontaneous IO firing rate (Lang, 2002), one could also expect tonic suppression of IN activity. We not only found that NBQX immediately abolishes CRs without the need for CS presentations (a condition required for extinction), but this behavioral response coincided with the immediate suppression of both spontaneous IN activity and task-related modulation (**Fig. 3**).

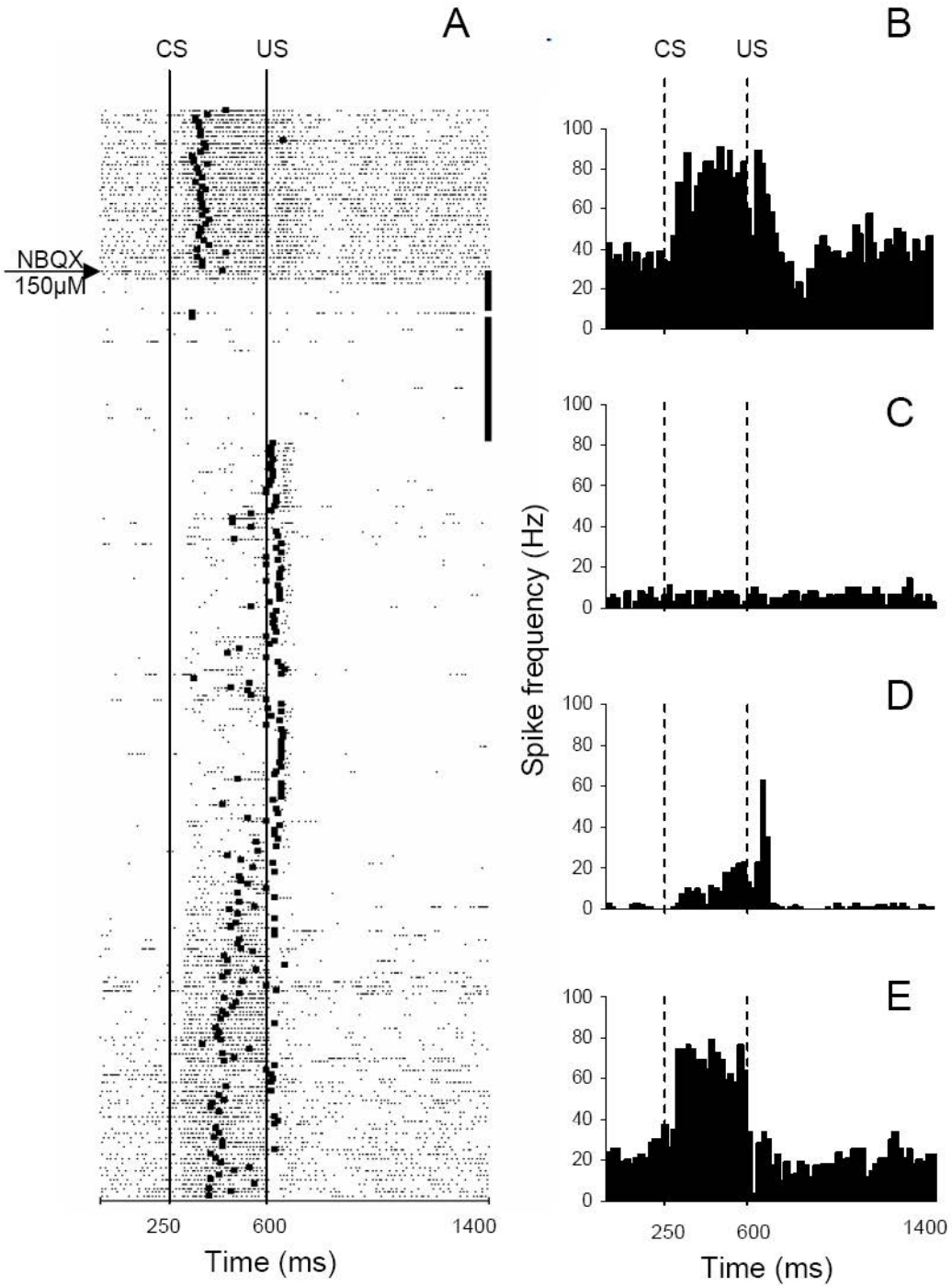

Figure 3. An example of the parallel effects of inferior olivary NBQX infusion on CR performance and on the activity of a task-modulated IN cell. This experiment consisted of 260 trials. After 40 baseline trials, NBQX was injected at the beginning of a 40-trial no-stimulation period. A, Raster plot of IN cell activity during this experiment. The experiment starts at the top with each row representing one trial, and each dot marking the occurrence of an action potential. The black square in each row corresponds to the onset of the eyeblink in that particular trial. Consequently, CRs have onset markers between lines denoting the CS and US onsets. Eyeblinks initiated past the US onset occur in trials in which the animal failed to produce the CR. Black squares at the ends of the 40 trials following the NBQX injection marker denote the no-stimulation waiting period that was inserted to allow for drug diffusion. Before the injection, this cell responded with excitation during the CS–US interval and with a combined excitatory/inhibitory response to the US. During the drug diffusion period, the firing rate of this cell’s activity precipitously declined. When stimulation was resumed, CRs were abolished immediately as evidenced by the blink onset marks on the right side of the US onset line. The baseline activity remained suppressed, and modulation during the CS–US interval was severely reduced whereas the relative excitatory modulation to the US became more distinct. The neuronal activity gradually recovered toward the end of the experiment in parallel with the recovery of behavioral CRs. B–E, Peri-stimulus histograms of the same IN unit constructed for 40 trials before the injection (B), for 40 post-injection drug diffusion trials when stimulation was paused (C), for 40 trials following the waiting period when stimulation was resumed (D), and for the last 40 trials from the remaining 140 trials of the experiment (E). Bin width for histograms in B–E is 20 ms. CS, onset of

conditioned stimulus; US, onset of unconditioned stimulus. (Reprinted with permission from Zbarska et al., 2008)

In the framework of the telecommunications network metaphor, the behavioral part of our study argued against the cerebellar learning hypothesis. However, our electrophysiological data revealed that this metaphor had a major shortcoming affecting the interpretation of the findings – its failure to recognize the importance of a fundamental variable, the tonic interactions in cerebellar networks. The intent of the above IO studies was to observe the consequences of blocking the IO error signal to the cerebellum. However, the IO injection of NBQX also made the cerebellar cortex and nuclei dysfunctional by blocking the cerebellar output, which in turn results in the abolition of CRs, precluding any conclusions about the mechanisms and sites involved in establishing plasticity.

Additional evidence for cerebellar tonic interactions following manipulations of the cerebellar circuitry emerged when we examined GABA and glutamate neurotransmission in the IN of trained rabbits. Individual contributions of the cerebellar cortex and IN to CR acquisition and expression have been the subject of a long-standing debate. In an attempt to resolve this issue, some investigators proposed that nuclear components of learning could be revealed by blocking GABA-ergic projections of Purkinje cells to the IN (Medina et al., 2001; Ohyama et al., 2006). They reported that blocking GABA-A receptors either with picrotoxin or with gabazine shortens the latency of CRs. The authors proposed that short-latency CRs are a manifestation of nuclear plasticity that is revealed in the absence of cerebellar cortical input. In their computer simulations, Medina et al. (2001) predicted that

injecting picrotoxin in the IN should affect the time profile of IN neuronal responses but should have no effect on their spontaneous activity. Relevant to the subject of this review, these simulations are based on the telecommunications network metaphor because they did not consider tonic interactions.

To examine these proposals, we injected the IN of trained rabbits with GABA agonists and antagonists and then measured their effect on IN single-unit activity and on CRs (Aksenov et al., 2004). In our experiments, we could not confirm their prediction that effects would be limited to IN neuronal response timing. Instead, we found that a partial block of chloride channels with picrotoxin dramatically increased IN tonic activity. A more complete block of GABA neurotransmission with larger amounts of picrotoxin further increased IN spontaneous activity. It became so high that practically all modulation was suppressed, and behavioral CRs were abolished (**Fig. 4**). Although the goal of these experiments was to block signals embedded in Purkinje cell firing without altering normal IN activity, our recordings demonstrated that the functional state of the IN was dramatically altered. Furthermore, it is also likely that the excitability of IN efferent targets was also modified. This distributed functional abnormality prevented any conclusions about the cerebellar cortical and IN roles in CR expression. We conclude that simply blocking GABA neurotransmission in the IN can not address these questions.

The examples of tonic interactions in cerebellar circuits demonstrate that local inactivation and pharmacological manipulation are imperfect tools when used to interfere with task-related signals or to block local information processing. This is because local interventions will inevitably alter normal spontaneous activity of manipulated structures, and

this abnormality will spread to down-stream parts of the network. This problem is further exacerbated by participation of feedback loops that provide a path for the propagation of the tonic change to up-stream parts of the network. The spread of tonic changes via the cerebello-olivary-cerebellar feedback loop has been documented. Hesslow and colleagues recorded a dramatic reduction of spontaneous Purkinje cell activity when inactivating IN axons in the brachium conjunctivum of decerebrate ferrets (Svensson et al., 2005; Bengtsson et al., 2004), findings which are consistent with results from our laboratory. We found that inactivating the BC in classically conditioned rabbits elevates the tonic activity of upstream IN neurons (Nilaweera et al., 2002). In summary, combined microinjection and recording studies demonstrate that local manipulations alter spontaneous activity and that this change can spread via tonic interactions to both down-stream and up-stream parts of the network.

The down-stream and recurrent propagation of tonic changes is highly pertinent to the interpretation of studies in which components of the cerebellar circuits are inactivated during learning. In previous sections we have shown that, when viewed through the perspective of the telecommunications network metaphor, the collective results of experiments in which this methodology was used point to the existence of extra-cerebellar sites for plasticity underlying this behavior. However, given the potential for recurrent and downstream spread of tonic changes, the failure to acquire CRs during BC inactivation does not prove extra-cerebellar learning. It is possible that this treatment also affected cerebellar learning via tonic malfunction within the cerebello-olivary-cerebellar feedback loop. As a result, despite the initial optimism regarding the use of reversible lesions, inactivating parts of cerebellar

circuits during training actually tells us surprisingly little about the location of plastic changes.

5.6 Cerebellar learning vs. network performance hypotheses

As argued above, the telecommunications network metaphor can't explain the results of experiments that inactivate neurons or block neurotransmission in eyeblink conditioning circuits. A more realistic conceptualization of how these circuits function has to include tonic phenomena. Eyeblink circuits should be viewed not only as a network of nodes that process and transmit task-related signals but also as a spontaneously active, recurrent neuronal network with strong tonic interactions.

Nevertheless, addressing such concepts as the cerebellar learning hypothesis can not proceed without using intervention methods if we are to understand the fundamental mechanisms responsible for motor learning phenomena like the classically conditioned eyeblink reflex. Only interfering with information processing within the putative learning-related substrates can confirm or disprove this view and evaluate its importance for learning at a systems level. The problem is that traditional intervention experiments, such as local inactivation or blocking specific neurotransmitter systems, up- or down-regulate spontaneous neuronal activity, thus complicating the interpretation of findings. For example, based on the telecommunications network metaphor, our study in which CR acquisition was blocked by BC inactivation (Nilaweera et al., 2006) suggests that extra-cerebellar learning definitely occurs. However, when the associated tonic changes of spontaneous activity are considered, an alternate, more parsimonious explanation – *the network performance hypothesis* – emerges as a basis for the majority of observations. This hypothesis proposes that the effects

of manipulating cerebellar circuits are related to a non-specific, wide-spread malfunction of the networks responsible for acquiring and/or expressing CRs. Interestingly, we know that in the case of BC inactivation, the network performance hypothesis is correct, because blocking the BC alters tonic activity in the IO, cerebellar cortex (Bengtsson et al., 2004) and IN (Nilaweera et al., 2002), and most likely also in mesencephalic targets of cerebellar efferents. Does this mean that these BC inactivation studies disprove the cerebellar learning hypothesis? Not necessarily. In fact, both hypotheses could be correct because the cerebellar learning and performance hypotheses are not mutually exclusive nor are they truly antithetical. Rather, the network performance hypothesis proposes that the relevant findings are due to an abnormal functional state of the cerebellar circuitry. Consequently, no definite conclusions about cerebellar learning can be inferred. Advancing our understanding of the neural circuitry subserving eyeblink conditioning will require intervention methods that eliminate the abnormalities on which the network performance hypothesis is based.

5.7 Dissociating learning from network performance-related phenomena

An obvious solution for dissociating learning from network performance abnormalities would be the use of approaches that preserve spontaneous neuronal activity or that target processes insensitive to tonic changes. In our view, three promising research strategies are compatible with these goals.

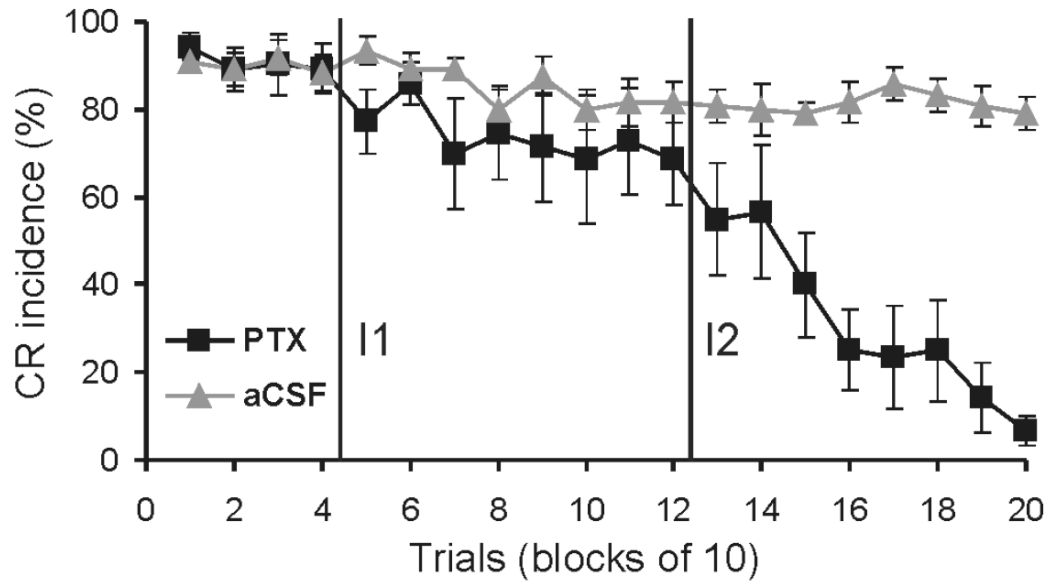

IN neuronal activity (n=55)

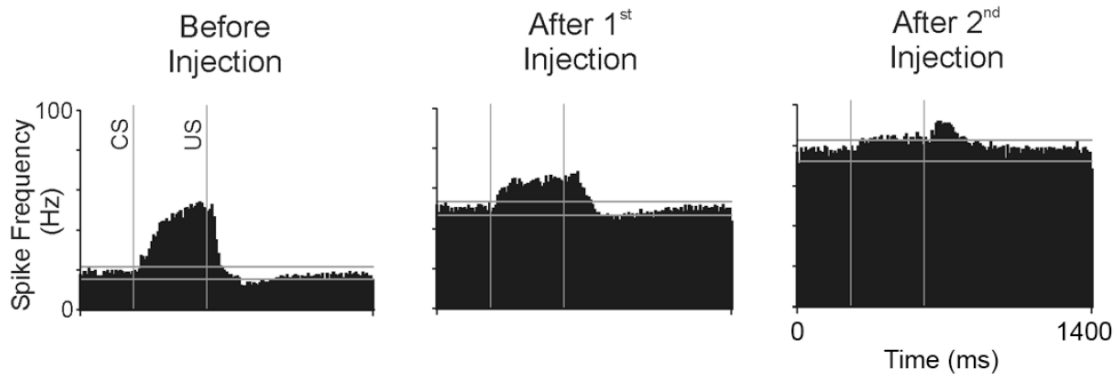

Figure 4. Effects of injecting the IN with the chloride channel blocker, picrotoxin (PTX), on the expression of CRs and on IN neuronal activity. Top panel: CR incidence in 15 injection experiments in which two injections of PTX were applied to the IN. The first injection (I1) had only a small effect on the frequency of CRs. A more extensive block of GABA-ergic

neurotransmission with the second PTX injection (I2) gradually abolished CRs. Control injections of vehicle (aCSF) did not affect CR incidence. Bottom panel: population peri-stimulus histograms of 55 neurons recorded during PTX injections. Before injections, this population exhibited approximately a 25 Hz spontaneous firing rate and an excitatory response in the CS-US interval. The first PTX injection doubled the spontaneous discharge of IN neurons and reduced their CS-related modulation. Following the second injection, the spontaneous activity further increased, and the responses in the CS-US interval were almost completely attenuated. Two horizontal lines in each histogram denote tolerance limits used for detecting significant levels of neuronal modulation relative to mean baseline activity (Adapted from Aksenov et al., 2004).

In theory, not all cerebellar learning-related processes have to be sensitive to cerebellar tonic malfunction. A possible candidate for such a process could be memory consolidation which takes place after signaling events that induce learning in eyeblink circuits have already occurred and therefore could not be perturbed by tonic phenomena. Attwell et al. (2002) reported that infusions of muscimol in the eyeblink area of the cerebellar cortex following training sessions prevented CR acquisition by interfering with memory consolidation. Interestingly, injecting muscimol in the deep cerebellar nuclei did not affect CR consolidation. Based on these results, Attwell et al. concluded that a muscimol-sensitive memory consolidation process in the cerebellar cortex is required for eyeblink conditioning. This finding, however, does not exclude consolidation of plastic changes in the IN or in

extra-cerebellar sites that could be insensitive to IN inactivation and associated tonic changes in the circuit.

Another promising approach involves methods that could interfere with the putative cellular substrates of learning without affecting normal neuronal activity. An example of the successful use of this strategy is our study in which we blocked the synthesis of new proteins in the IN during CR acquisition sessions (Bracha et al., 1998). We found that infusing the IN with anisomycin suppressed CR acquisition. Since anisomycin has been reported to have minimal effects on spontaneous neuronal activity, this finding can be considered among the best evidence for cerebellar learning. Besides their potential for success, tools targeting possible cellular mechanisms of learning also have their limitations. The most important limitation of methods in this category is that they are not suited for analyzing the role of task-related signals during learning. For instance, blocking protein synthesis in the IN can't determine which inputs to the IN trigger the protein synthesis-dependent learning mechanism.

The third category of approaches that could separate learning from abnormalities in network performance consists of combined applications of receptor agonists and antagonists. The tremendous potential of this approach was shown for the first time by Bao et al. (2002), who discovered that CRs suppressed by infusing a GABA-A agonist, muscimol, in the IN can be recovered by the subsequent infusion of the chloride channel blocker, picrotoxin. We were able to replicate these data (Aksenov et al., 2004; Aksenov et al., in preparation). Our single-unit recordings in injected animals confirmed that muscimol-induced CR suppression was accompanied by inhibition of IN neurons: their spontaneous firing was suppressed. The

subsequent infusion of picrotoxin reduced the inhibition and restored spontaneous firing to its near normal rate, but the amplitude of event-related responses was reduced (Aksenov et al., 2004). Surprisingly, this group of observations was paralleled by the partial restoration of CRs. Because these studies blocked Purkinje cell input to the IN without markedly disrupting IN spontaneous activity, they were the first to eliminate the network performance hypothesis in experiments blocking network communication. The fundamental implication of these observations is that the IN can support CR expression in the absence of cerebellar cortical inputs. Did the remaining modulation of IN neurons generate the recovered CRs? To examine this issue, we again infused the IN with muscimol to block cerebellar cortical input, but in addition, a fast glutamate receptor blocker DGG was injected to block direct IN input from collaterals of mossy and climbing fibers. This treatment suppressed both IN activity and CR expression. Follow-up injections of PTX restored IN spontaneous firing, but all event-related modulation was suppressed. Yet, even in this condition CRs were partially restored (Aksenov et al., 2004). This finding strongly suggests that the modulation of IN neurons is not required for the expression of these residual CRs. Such CRs do not seem to require motor commands from the cerebellum, supporting the argument that these CRs are most likely controlled by extra-cerebellar components of eyeblink circuits.

5.8 Conclusion

In conclusion, we have shown that the basis for the dependency of eyeblink conditioning on cerebellar circuits is not completely understood. The most investigated concept, the cerebellar learning hypothesis, assumes learning occurs in the cerebellar cortex, the deep cerebellar nuclei, or more recently – in both of these locations. However, because

of difficulties in dissociating the learning and network performance hypotheses, the cerebellar learning hypothesis has not been supported by unequivocal, direct evidence from lesion or inactivation studies. Unless future intervention studies successfully manipulate putative conditioned eyeblink substrates without altering levels of spontaneous activity, the specific roles of the cerebellum in acquiring, expressing, and retaining classically conditioned eyeblinks will remain elusive.

Recent developments have identified new approaches that could minimize the impact of cerebellar tonic phenomena. Although the development of these new tools is still in its infancy, efforts in that direction have already revealed very promising results indicating plasticity in several cerebellar and extra-cerebellar parts of eyeblink circuits. Previously we proposed, mostly based on indirect evidence, that plastic changes supporting eyeblink conditioning are distributed across several components of eyeblink conditioning networks (Bracha and Bloedel, 1996; Bracha et al., 2001). We speculated that all nodes that receive the information about the CS and US, including sites within the cerebellum, could be sites of plasticity underlying learning (**Fig. 2**, sites labeled with a star). This position appears to be supported by the available data: (1) consolidation experiments suggesting cerebellar cortical involvement; (2) the dependency of CR acquisition on the synthesis of new proteins in the IN suggesting an important role for cerebellar nuclei; and (3) combined infusions of GABA and glutamate receptor ligands in the IN indicating that CRs are supported at least partially by extra-cerebellar substrates. These data mandate that future research should focus on examining the role of both cerebellar and extra-cerebellar sites in the classical conditioning

of the eyeblink reflex. The continued application of novel approaches will lead to the resolution of these questions in the relatively near future.

5.9 References

- Aksenov D, Serdyukova N, Irwin K, Bracha V (2004) GABA neurotransmission in the cerebellar interposed nuclei: involvement in classically conditioned eyeblinks and neuronal activity. *J Neurophysiol* 91: 719-727.
- Aksenov D, Serdyukova N, Bloedel JR, Bracha V (2004) The role of tonic activity and phasic modulation of interposed cerebellar nuclear cells in the expression of conditioned eyeblinks. 136.6. *2004 Abstract Viewer/Itinerary Planner*. Washington, DC: Society for Neuroscience.
- Albus, J. S. (1971) A theory of cerebellar function. *Math. Biosci.* 10, 25-61.
- Attwell PJ, Cooke SF, Yeo CH (2002a) Cerebellar function in consolidation of a motor memory. *Neuron* 34: 1011-1020.
- Attwell PJ, Ivarsson M, Millar L, Yeo CH (2002b) Cerebellar mechanisms in eyeblink conditioning. *Ann N Y Acad Sci* 978: 79-92.
- Attwell PJ, Rahman S, Yeo CH (2001) Acquisition of eyeblink conditioning is critically dependent on normal function in cerebellar cortical lobule HVI. *J Neurosci* 21: 5715-5722.

- Bao S, Chen L, Kim JJ, Thompson RF (2002) Cerebellar cortical inhibition and classical eyeblink conditioning. *Proc Natl Acad Sci U S A* 99: 1592-1597.
- Batini C, Billard JM, Daniel H (1985) Long-term modification of cerebellar inhibition after inferior olive degeneration. *Exp Brain Res* 59: 404-409.
- Bengtsson F, Svensson P, Hesslow G (2004) Feedback control of Purkinje cell activity by the cerebello-olivary pathway. *Eur J Neurosci* 20: 2999-3005.
- Berthier NE, Moore JW (1986) Cerebellar Purkinje cell activity related to the classically conditioned nictitating membrane response. *Exp Brain Res* 63: 341-350.
- Berthier NE, Moore JW (1990) Activity of deep cerebellar nuclear cells during classical conditioning of nictitating membrane extension in rabbits. *Exp Brain Res* 83: 44-54.
- Billard JM, Batini C, Daniel H (1988) The red nucleus activity in rats deprived of the inferior olivary complex. *Behav Brain Res* 28: 127-130.
- Bloedel JR, Bracha V (1995) On the cerebellum, cutaneomuscular reflexes, movement control and the elusive engrams of memory. *Behav Brain Res* 68: 1-44.
- Bracha V, Bloedel JR (1996) The multiple pathway model of circuits subserving the classical conditioning of withdrawal reflexes. In: *Acquisition of Motor Behavior in Vertebrates* (Bloedel JR, Ebner TJ, Wise SP, eds), pp 175-204. Cambridge: MIT Press.

Bracha V, Irwin KB, Webster ML, Wunderlich DA, Stachowiak MK, Bloedel JR (1998)

Microinjections of anisomycin into the intermediate cerebellum during learning affect the acquisition of classically conditioned responses in the rabbit. *Brain Res* 788: 169-178.

Bracha V, Kolb FP, Irwin KB, Bloedel JR (1999) Inactivation of interposed nuclei in the cat: classically conditioned withdrawal reflexes, voluntary limb movements and the action primitive hypothesis. *Exp Brain Res* 126: 77-92.

Bracha V, Zhao L, Irwin K, Bloedel JR (2001) Intermediate cerebellum and conditioned eyeblinks. Parallel involvement in eyeblinks and tonic eyelid closure. *Exp Brain Res* 136: 41-49.

Carrea, RME, Reissig, M, Mettler, FA (1947) The climbing fibers of the simian and feline cerebellum; experimental inquiry into their origin by lesions of the inferior olives and deep cerebellar nuclei. *J. Comp. Neurol.* 87: 371-365.

Cartford MC, Gohl EB, Singson M, Lavond DG (1997) The effects of reversible inactivation of the red nucleus on learning-related and auditory-evoked unit activity in the pontine nuclei of classically conditioned rabbits. *Learning and Memory* 3: 519-531.

Chen L, Bao SW, Lockard JM, Kim JJ, Thompson RF (1996) Impaired classical eyeblink conditioning in cerebellar-lesioned and Purkinje cell degeneration (*pcd*) mutant mice. *J Neurosci* 16: 2829-2838.

Christian KM, Thompson RF (2003) Neural substrates of eyeblink conditioning: acquisition and retention. *Learn Mem* 10: 427-455.

Clark GA, McCormick DA, Lavond DG, Thompson RF (1984) Effects of lesions of cerebellar nuclei on conditioned behavioral and hippocampal neuronal responses. *Brain Res* 291: 125-136.

Clark RE, Lavond DG (1993) Reversible lesions of the red nucleus during acquisition and retention of a classically conditioned behavior in rabbits. *Behav Neurosci* 107: 264-270.

De Zeeuw CI, Yeo CH (2005) Time and tide in cerebellar memory formation. *Curr Opin Neurobiol* 15: 667-674.

Dow RS, Moruzzi G (1958) *The physiology and pathology of the cerebellum*. Minneapolis: University of Minnesota Press.

Hardiman MJ, Ramnani N, Yeo CH (1996) Reversible inactivations of the cerebellum with muscimol prevent the acquisition and extinction of conditioned nictitating membrane responses in the rabbit. *Exp Brain Res* 110: 235-247.

Hausser M, Raman IM, Otis T, Smith SL, Nelson A, Du Lac S, Loewenstein Y, Mahon S, Pennartz C, Cohen I, Yarom Y (2004) The beat goes on: Spontaneous firing in mammalian neuronal microcircuits. *J Neurosci* 24: 9215-9219.

Kim JJ, Krupa DJ, Thompson RF (1998) Inhibitory cerebello-olivary projections and blocking effect in classical conditioning. *Science* 279: 570-573.

- Kolb FP, Irwin KB, Bloedel JR, Bracha V (1997) Conditioned and unconditioned forelimb reflex systems in the cat: involvement of the intermediate cerebellum. *Experimental Brain Res* 114: 255-270.
- Krupa DJ, Thompson JK, Thompson RF (1993) Localization of a memory trace in the mammalian brain. *Science* 260: 989-991.
- Lang EJ (2002) GABAergic and glutamatergic modulation of spontaneous and motor-cortex-evoked complex spike activity. *J Neurophysiol* 87: 1993-2008.
- Lye RH, O'Boyle DJ, Ramsden RT, Schady W (1988) Effects of the unilateral cerebellar lesion on the acquisition of the eye-blink conditioning in man. *J Physiol (Lond)* 403: 58.
- MacKay WA, Murphy JT (1979) Cerebellar modulation of reflex gain. *Progress in Neurobiology* 13: 361-417.
- Marr D (1969) A theory of cerebellar cortex. *J Physiol* 202: 437-470.
- McCormick DA, Steinmetz JE, Thompson RF (1985) Lesions of the inferior olivary complex cause extinction of the classically conditioned eyeblink response. *Brain Res* 359: 120-130.
- Medina JF, Garcia KS, Mauk MD (2001) A mechanism for savings in the cerebellum. *J Neurosci* 21: 4081-4089.

- Medina JF, Nores WL, Mauk MD (2002) Inhibition of climbing fibres is a signal for the extinction of conditioned eyelid responses. *Nature* 416: 330-333.
- Montarolo PG, Palestini M, Strata P (1982) The inhibitory effect of the olivocerebellar input on the cerebellar Purkinje cells in the rat. *J Physiol* 332: 187-202.
- Nilaweera WU., Irwin KB, Zenitsky GD, Aksenov DP, Bracha V (2002) Are feedback loops involved in the formulation of cerebellar neuronal correlates of conditioned eyeblinks? *Soc.Neurosci.Abstr.* 79.6.
- Nilaweera WU, Zenitsky GD, Bracha V (2006) Inactivation of cerebellar output axons impairs acquisition of conditioned eyeblinks. *Brain Res* 1122: 143-153.
- Ohyama T, Medina JF, Nores WL, Mauk MD (2002) Trying to understand the cerebellum well enough to build one. *Ann N Y Acad Sci* 978: 425-438.
- Ohyama T, Nores WL, Medina JF, Riusech FA, Mauk MD (2006) Learning-induced plasticity in deep cerebellar nucleus. *J Neurosci* 26: 12656-12663.
- Skelton RW (1988) Bilateral cerebellar lesions disrupt conditioned eyelid responses in unrestrained rats. *Behav Neurosci* 102: 586-590.
- Solomon PR, Stowe GT, Pendlebury WW (1989) Disrupted eyelid conditioning in a patient with damage to cerebellar afferents. *Behav Neurosci* 103: 898-902.

- Svensson P, Bengtsson F, Hesslow G (2005) Cerebellar inhibition of inferior olivary transmission in the decerebrate ferret. *Exp Brain Res* 1-13.
- Thompson RF (1986) The neurobiology of learning and memory. *Science* 233: 941-947.
- Timmann D, Baier PC, Diener HC, Kolb FP (2000) Classically conditioned withdrawal reflex in cerebellar patients. 1. Impaired conditioned responses. *Exp Brain Res* 130: 453-470.
- Voneida TJ, Christie D, Bogdanski R, Chopko B (1990) Changes in instrumentally and classically conditioned limb-flexion responses following inferior olivary lesions and olivocerebellar tractotomy in the cat. *J Neurosci* 10: 3583-3593.
- Welsh JP, Harvey JA (1998) Acute inactivation of the inferior olive blocks associative learning. *Eur J Neurosci* 10: 3321-3332.
- Yeo CH, Hardiman MJ, Glickstein M (1985) Classical conditioning of the nictitating membrane response of the rabbit. I. Lesions of the cerebellar nuclei. *Exp Brain Res* 60: 87-98.
- Zbarska S, Bloedel JR, Bracha V (2008) Cerebellar dysfunction explains the extinction-like abolition of conditioned eyeblinks after NBQX injections in the inferior olive. *J of Neurosci* 28: 10-20.

Zbarska S, Holland EA, Bloedel JR, Bracha V (2007) Inferior olivary inactivation abolishes conditioned eyeblinks: extinction or cerebellar malfunction? Behav Brain Res 178: 128-138.

CHAPTER 6: THE ROLE OF IN NEURONAL ACTIVITY IN THE CONTROL OF REFLEXIVE AND VOLUNTARY MOVEMENTS

A paper published as part of a multi-author consensus paper in the journal “*Cerebellum*”¹³

V. Bracha^{14,15}, A.J. Carrel¹⁴

6.1 Abstract

In the present consensus paper, we examine the role of the cerebellar interpositus nucleus (IN). Recent findings are considered, including: IN as part of the olivo-cortico-nuclear microcircuits involved in providing powerful timing signals important in coordinating limb movements; the possible participation of IN in the timing and performance of ongoing conditioned responses rather than the generation and/or initiation of such responses; a role of IN in the modulation of autonomic and emotional functions; the control of reflexive and voluntary movements in a task- and effector system-dependent fashion, including hand movements and associated upper limb adjustments for quick effective actions, and, finally, in the development of internal models for dynamic interactions of the motor system with the external environment, for anticipatory control of movement.

6.2 Review

¹³ Reprinted with permission of “*Cerebellum*”, 2012.

¹⁴ Department of Biomedical Sciences, Iowa State University.

¹⁵ Primary researcher and corresponding author.

The cerebellar anterior and posterior interposed nuclei (IN) represent the sole output of the intermediate cerebellum. The largest sub-population of IN cells comprises glutamatergic neurons that project to the contralateral red nucleus and also to other mesencephalic, thalamic and pontine targets. These neurons control movements of ipsilateral limbs, facial musculature and also some aspects of eye movements.

What is encoded in the activity of IN neurons? The answer to this question is partly based on studies that recorded single-unit activity of these cells during a variety of behaviors. It is known that IN neurons are somatotopically organized (Rispoli-Padel et al., 1982, Asanuma et al., 1983, van Kan et al., 1993) and that appropriate neurons modulate their activity in correlation with task-related sensory inputs, with movements of ipsilateral limbs during locomotion and reaching, with reflexive movements of facial musculature, such as eyeblinks, and with eye vergence and accommodation (Schwartz et al., 1987, Berthier and Moore, 1990, van Kan et al., 1994, Gibson et al., 1996, Zhang and Gamlin, 1998, Chen and Evinger, 2006, Sanchez-Campusano et al., 2007). The movement-related IN signals can both precede and follow movement initiation, indicating their involvement in generating and shaping movements. Assessing the functional significance of these IN task-related signals requires examining how blocking them affects associated behaviors.

The most common method of blocking IN signals has been the temporary inactivation of IN neurons with the GABA-A agonist muscimol. It has been shown that injecting the IN with muscimol has a diverse array of task-dependent effects on reflexive and voluntary movements. Perhaps the most striking effect of IN inactivation is a complete suppression of classically conditioned withdrawal reflexes, such as eyeblink and limb flexion reflexes

(Krupa et al., 1993, Bracha et al., 1994, Kolb et al., 1997). In contrast, muscimol suppresses, but doesn't abolish, unconditioned eyeblinks (Bracha et al., 1994) and limb withdrawals (Kolb et al., 1997). Pertinent to IN function, muscimol injections don't block all associations between the conditioned and unconditioned stimuli because the learned postural preparation necessary for limb withdrawal is not affected (Kolb et al., 1997). Besides classically conditioned withdrawal reflexes, IN inactivation also blocks instrumentally conditioned eyeblinks (Kreider and Mauk, 2010), and instrumentally conditioned tonic eyelid closure (Bracha et al., 2001). Other limb cutaneo-muscular reflexes, such as tactile placing, magnet and hopping reflexes, are also severely suppressed by IN inactivation (Kolb et al., 1997). In addition, IN inactivation was shown to affect several aspects of reaching-to-grasp movements, the feed-forward adaptation to perturbations of reaching movements and the precision hand/foot placement during reaching, walking and climbing (Milak et al., 1997, Bracha et al., 1999, Martin et al., 2000, Horn et al., 2010).

While IN recording and inactivation studies provided important insights into IN function, our knowledge of the functional significance of IN signals remains incomplete. The main short-coming of the IN inactivation method is that it affects not only signals generated and/or transmitted by the IN, but also its spontaneous activity. Specifically, muscimol completely silences IN neurons (Aksenov et al., 2004). Thus, behavioral effects of muscimol could be either partly or completely caused not by the absence of IN signals, but rather by the loss of spontaneous activity-mediated excitatory drive to IN efferent targets (Bracha et al., 2009). Deciphering the functional role of IN output signals requires new approaches that

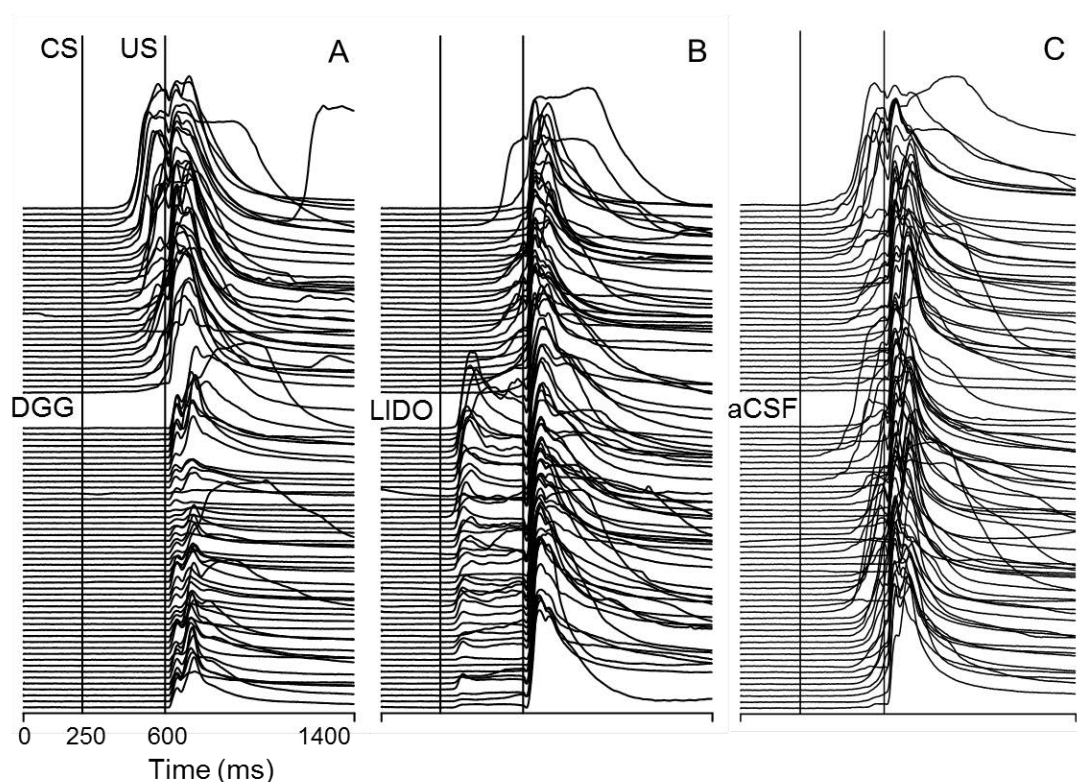

Figure 1. Blocking glutamate transmission in eyeblink-related area of HVI with DGG (A) abolishes CRs, whereas injecting the same site with lidocaine (B) yields short-latency CRs. Printout of raw eyeblink data from three experiments on one rabbit. The animal was microinjected (2 ul) on separate days with DGG, lidocaine and vehicle in the same eyeblink-related region of HVI. The experiments start at the top with each horizontal eyeblink trace representing one CS-US trial. Microinjections were delivered after 40 pre-injection trials. (A) After injecting DGG (200 nmol), CRs (upward deflections between the CS and US markers) were abolished immediately. (B) Lidocaine (LIDO, 4%) also had an immediate effect on CRs. However, instead of abolishing them, it shortened CR latencies. (C) The control experiment reveals that the vehicle (aCSF) had no effect on CRs.

would selectively block the modulation of IN neurons with minimal effects on their spontaneous firing.

Promising in this regard are recent eyeblink conditioning studies. The IN receive two relevant inputs: GABA-ergic projections from Purkinje cells (PCs) of the cerebellar cortex representing the main input, and an anatomically weaker glutamatergic input from collaterals of mossy and climbing fibers. In theory, selective blocking of incoming signals could address the role of IN signals more efficiently. Blocking collateral inputs with glutamate antagonists was shown to have weak effects on IN modulation and spontaneous activity and it does not abolish behavioral CRs (Attwell et al., 2002b, Aksenov et al., 2005, Ohyama et al., 2006). This suggests that CR-related signals are largely produced by GABA-ergic input from PCs. Pharmacologically blocking the PC's input directly in the IN is impractical because both GABA agonists and antagonists have major effects on the spontaneous activity of IN neurons (Aksenov et al., 2004). An interesting alternative could be blocking the incoming cortical signals at their place of origin in the cerebellar cortex. Results from studies implementing this approach are conflicting. It has been shown that injections of lidocaine into the cortical lobule HV shorten CR latency (Kalmbach et al., 2010). On the other hand, injections of the glutamate antagonist CNQX into the adjacent lobule HVI abolish CRs (Mostofi et al., 2010).

In our ongoing examination of these conflicting claims we found that both effects can be evoked from the same cortical site (Fig. 1). Lidocaine inactivation of the eyeblink-related portion of HVI produced short-latency CRs and tonic eyelid closure. Somewhat counter-intuitively, injecting the same site with the glutamate antagonist DGG abolished CRs and had

no effect on tonic eyelid closure. Why would these two methods of blocking cortical signals at the same site produce diametrically opposite behavioral effects? The likely explanation for this observation is that while both drugs block eyeblink-related cortical signals, only DGG does it without perturbing IN spontaneous activity. This finding strongly indicates that IN signals are required for CR initiation. Lidocaine on the other hand, by virtue of blocking all PC output, disinhibits IN neurons. The ensuing increased excitability of the IN and of extra-cerebellar circuits is responsible for abnormal "CR-like" responses. If confirmed, blocking cortical signals with glutamate antagonists could become a powerful tool for examining the functional significance of signals generated by the IN.

A number of excellent neurophysiological studies determined that IN signals control movements in a task- and effector system-dependent fashion. Deciphering the precise contribution of these signals remains a challenge that will require new approaches for suppressing them without adversely affecting the general functional state of intermediate cerebellar neuronal networks.

6.3 References

Aksenov, D., N. Serdyukova, et al. (2004). "GABA neurotransmission in the cerebellar interposed nuclei: involvement in classically conditioned eyeblinks and neuronal activity." Journal of neurophysiology **91**(2): 719-727.

Aksenov, D. P., N. A. Serdyukova, et al. (2005). "Glutamate neurotransmission in the cerebellar interposed nuclei: involvement in classically conditioned eyeblinks and neuronal activity." Journal of neurophysiology **93**(1): 44-52.

- Asanuma, C., W. R. Thach, et al. (1983). "Anatomical evidence for segregated focal groupings of efferent cells and their terminal ramifications in the cerebellothalamic pathway of the monkey." Brain research **286**(3): 267-297.
- Attwell, P. J., M. Ivarsson, et al. (2002). "Cerebellar mechanisms in eyeblink conditioning." Annals of the New York Academy of Sciences **978**: 79-92.
- Berthier, N. E. and J. W. Moore (1990). "Activity of deep cerebellar nuclear cells during classical conditioning of nictitating membrane extension in rabbits." Experimental brain research. Experimentelle Hirnforschung. Experimentation cerebrale **83**(1): 44-54.
- Bracha, V., F. P. Kolb, et al. (1999). "Inactivation of interposed nuclei in the cat: classically conditioned withdrawal reflexes, voluntary limb movements and the action primitive hypothesis." Experimental brain research. Experimentelle Hirnforschung. Experimentation cerebrale **126**(1): 77-92.
- Bracha, V., M. L. Webster, et al. (1994). "Effects of muscimol inactivation of the cerebellar interposed-dentate nuclear complex on the performance of the nictitating membrane response in the rabbit." Experimental brain research. Experimentelle Hirnforschung. Experimentation cerebrale **100**(3): 453-468.
- Bracha, V., S. Zbarska, et al. (2009). "The cerebellum and eye-blink conditioning: learning versus network performance hypotheses." Neuroscience **162**(3): 787-796.

- Bracha, V., L. Zhao, et al. (2001). "Intermediate cerebellum and conditioned eyeblinks. Parallel involvement in eyeblinks and tonic eyelid closure." Experimental brain research. Experimentelle Hirnforschung. Experimentation cerebrale **136**(1): 41-49.
- Chen, F. P. and C. Evinger (2006). "Cerebellar modulation of trigeminal reflex blinks: interpositus neurons." The Journal of neuroscience : the official journal of the Society for Neuroscience **26**(41): 10569-10576.
- Gibson, A. R., K. M. Horn, et al. (1996). "Activity of interpositus neurons during a visually guided reach." Canadian journal of physiology and pharmacology **74**(4): 499-512.
- Horn, K. M., M. Pong, et al. (2010). "Functional relations of cerebellar modules of the cat." The Journal of neuroscience : the official journal of the Society for Neuroscience **30**(28): 9411-9423.
- Kalmbach, B. E., T. Davis, et al. (2010). "Cerebellar cortex contributions to the expression and timing of conditioned eyelid responses." Journal of neurophysiology **103**(4): 2039-2049.
- Kolb, F. P., K. B. Irwin, et al. (1997). "Conditioned and unconditioned forelimb reflex systems in the cat: involvement of the intermediate cerebellum." Experimental brain research. Experimentelle Hirnforschung. Experimentation cerebrale **114**(2): 255-270.

- Kreider, J. C. and M. D. Mauk (2010). "Eyelid conditioning to a target amplitude: adding how much to whether and when." The Journal of neuroscience : the official journal of the Society for Neuroscience **30**(42): 14145-14152.
- Krupa, D. J., J. K. Thompson, et al. (1993). "Localization of a memory trace in the mammalian brain." Science **260**(5110): 989-991.
- Martin, J. H., S. E. Cooper, et al. (2000). "Differential effects of deep cerebellar nuclei inactivation on reaching and adaptive control." Journal of neurophysiology **83**(4): 1886-1899.
- Milak, M. S., Y. Shimansky, et al. (1997). "Effects of inactivating individual cerebellar nuclei on the performance and retention of an operantly conditioned forelimb movement." Journal of neurophysiology **78**(2): 939-959.
- Mostofi, A., T. Holtzman, et al. (2010). "Electrophysiological localization of eyeblink-related microzones in rabbit cerebellar cortex." The Journal of neuroscience : the official journal of the Society for Neuroscience **30**(26): 8920-8934.
- Ohyama, T., W. L. Nores, et al. (2006). "Learning-induced plasticity in deep cerebellar nucleus." The Journal of neuroscience : the official journal of the Society for Neuroscience **26**(49): 12656-12663.

- Rispal-Padel, L., F. Cicirata, et al. (1982). "Cerebellar nuclear topography of simple and synergistic movements in the alert baboon (*Papio papio*)." Experimental brain research. Experimentelle Hirnforschung. Experimentation cerebrale **47**(3): 365-380.
- Sanchez-Campusano, R., A. Gruart, et al. (2007). "The cerebellar interpositus nucleus and the dynamic control of learned motor responses." The Journal of neuroscience : the official journal of the Society for Neuroscience **27**(25): 6620-6632.
- Schwartz, A. B., T. J. Ebner, et al. (1987). "Responses of interposed and dentate neurons to perturbations of the locomotor cycle." Experimental brain research. Experimentelle Hirnforschung. Experimentation cerebrale **67**(2): 323-338.
- van Kan, P. L., K. M. Horn, et al. (1994). "The importance of hand use to discharge of interpositus neurones of the monkey." The Journal of physiology **480 (Pt 1)**: 171-190.
- van Kan, P. L., J. C. Houk, et al. (1993). "Output organization of intermediate cerebellum of the monkey." Journal of neurophysiology **69**(1): 57-73.
- Zhang, H. and P. D. Gamlin (1998). "Neurons in the posterior interposed nucleus of the cerebellum related to vergence and accommodation. I. Steady-state characteristics." Journal of neurophysiology **79**(3): 1255-1269.

CHAPTER 7: BLOCKING GABA_A NEUROTRANSMISSION IN THE INTERPOSED NUCLEI: EFFECTS ON CONDITIONED AND UNCONDITIONED EYEBLINKS

A paper published in the journal “*Brain Research*”¹⁶

K. L. Parker^{17,18}, S. Zbarska¹⁷, A. J. Carrel¹⁷, V. Bracha^{17,19}

7.1 Abstract

The interposed nuclei (IN) of the intermediate cerebellum are critical components of the circuits that control associative learning of eyeblinks and other defensive reflexes in mammals. The IN, which represent the sole output of the intermediate cerebellum, receive massive GABAergic input from Purkinje cells of the cerebellar cortex and are thought to contribute to the acquisition and performance of classically conditioned eyeblinks. The specific role of deep cerebellar nuclei and the cerebellar cortex in eyeblink conditioning are not well understood. One group of studies reported that blocking GABA_A neurotransmission in the IN altered the time profile of conditioned responses (CRs), suggesting that the main function of the cerebellar cortex is to shape the timing of CRs. Other studies reported that blocking GABA_A neurotransmission in the IN abolished CRs, indicating a more fundamental involvement of the cerebellar cortex in CR generation.

¹⁶ Reprinted with permission of “*Brain Research*”, 2009.

¹⁷ Department of Biomedical Sciences, Iowa State University.

¹⁸ Primary researcher.

¹⁹ Corresponding author.

When examining this controversy, we hypothesized that the behavioral effect of GABA_A blockers could be dose-dependent. The IN of classically conditioned rabbits were injected with high and low doses of picrotoxin and gabazine. Both GABA_A blockers produced tonic eyelid closure. A high dose of both drugs abolished CRs, whereas a less complete block of GABA_A-mediated inputs with substantially smaller drug doses shortened CR latencies. In addition, low doses of picrotoxin facilitated the expression of unconditioned eyeblinks evoked by trigeminal stimulation. These results suggest that the intermediate cerebellum regulates both associative and non-associative components of the eyeblink reflex, and that behavioral effects of blocking Purkinje cell action on IN neurons are related to collective changes in cerebellar signals and in the excitability of extra-cerebellar eyeblink circuits.

7.2 Introduction

The intermediate cerebellar cortex and interposed nuclei (IN) are important parts of circuits controlling the learning and expression of anticipatory withdrawal responses, such as classically conditioned eyeblinks (CRs). The IN are the output of the intermediate cerebellum, and GABAergic Purkinje cells of the cerebellar cortex are the main source of their innervation (Ito, 1984). As a consequence of this functional arrangement, studies manipulating GABA_A receptor-mediated neurotransmission in deep cerebellar nuclei offer important insights into cerebellar control of eyeblink motoneurons. It is known that activating GABA_A receptors with muscimol suppresses the modulation and spontaneous activity of IN neurons (Aksenov et al., 2004), and this treatment blocks expression of CRs (Krupa et al., 1993; Bracha et al., 1994). Effects of suppressing IN neuronal activity in

rabbits are not restricted to CRs. Cerebellar nuclear microinjections of muscimol also down-regulate the amplitude of airpuff-evoked unconditioned trigeminal eyeblinks (Bracha et al., 1994; Jimenez-Diaz et al., 2004) and block instrumental eyelid closure (Bracha et al., 2001). The inactivation data together with the fact that neuronal activity in intact IN correlates with stimuli and movements during conditioned and unconditioned blinks (Berthier and Moore, 1990; Aksenov et al., 2004; Jimenez-Diaz et al., 2004; Zbarska et al., 2008) suggest that the modulation of neuronal activity in the intermediate cerebellum, coupled with the out-going tonic excitatory drive, control a range of learned and reflexive eyeblink behaviors.

Additional understanding of the intermediate cerebellar role in eyeblink control can be gained from studies that block GABAergic neurotransmission in cerebellar output nuclei. In contrast to muscimol, infusing the IN with the chloride channel blocker picrotoxin (PTX) dramatically elevates the spontaneous firing of IN neurons and decreases modulation of their activity during CR expression (Aksenov et al., 2004). Thus far, behavioral effects of blocking cerebellar nuclear GABA neurotransmission were not studied systematically and several studies of CR performance yielded conflicting results. Mauk and Garcia (1998) reported that IN injections of picrotoxin or gabazine (GZ) invariably decreased CR latency, leading to so called short-latency conditioned responses (SLRs). In contrast, others reported that IN infusions of PTX abolish CRs (Mamounas et al., 1987; Attwell et al., 2002; Aksenov et al., 2004). The cause of these variable PTX effects is not clear.

Based on our previous report of a dose-dependent effect of PTX on IN neuronal activity (Aksenov et al., 2004), we propose that behavioral outcomes of injecting the IN with GABA_A receptor antagonists are related to the extent of the block. We hypothesized that a

partial disruption of GABAergic neurotransmission in eyeblink-related neurons should produce SLRs and that a complete block of inhibitory inputs will abolish CRs. To address this hypothesis, we infused the IN of classically conditioned rabbits with low and high doses of GABA antagonists. In the second part of this study we investigated the parallel effects of PTX infusions on CRs and inborn visual and trigeminal unconditioned responses (URs). Here we report that a more complete block of GABA_A receptor-mediated neurotransmission with high doses of PTX and GZ abolished CRs. In contrast, lower doses of PTX and GZ produced SLRs, increased tonic eyelid closure, and facilitated unconditioned trigeminal eyeblinks.

7.3 Results

7.3.1 General observations

When injected in the IN at sites where previous small injections of muscimol abolished CR expression, both GZ and PTX had a dose-dependent effect on eyeblink expression. At small doses, both drugs shortened CR latency and increased tonic eyelid closure. In addition, low-dose PTX increased the amplitude of URs to a weak airpuff US and altered the velocity and duration of URs evoked by the normal airpuff intensity. At higher doses both drugs suppressed CRs. Besides their effect on eyelid movements, both drugs exaggerated responses to the airpuff US causing a more generalized withdrawal response encompassing neck and forelimb movements that drew the animal's head away from the air stimulation. Notably, tonic eyelid closure and withdrawal-related postural asymmetry disappeared immediately after the animal was removed from the restraint box. All of these

effects were observed at injection sites 1

ante

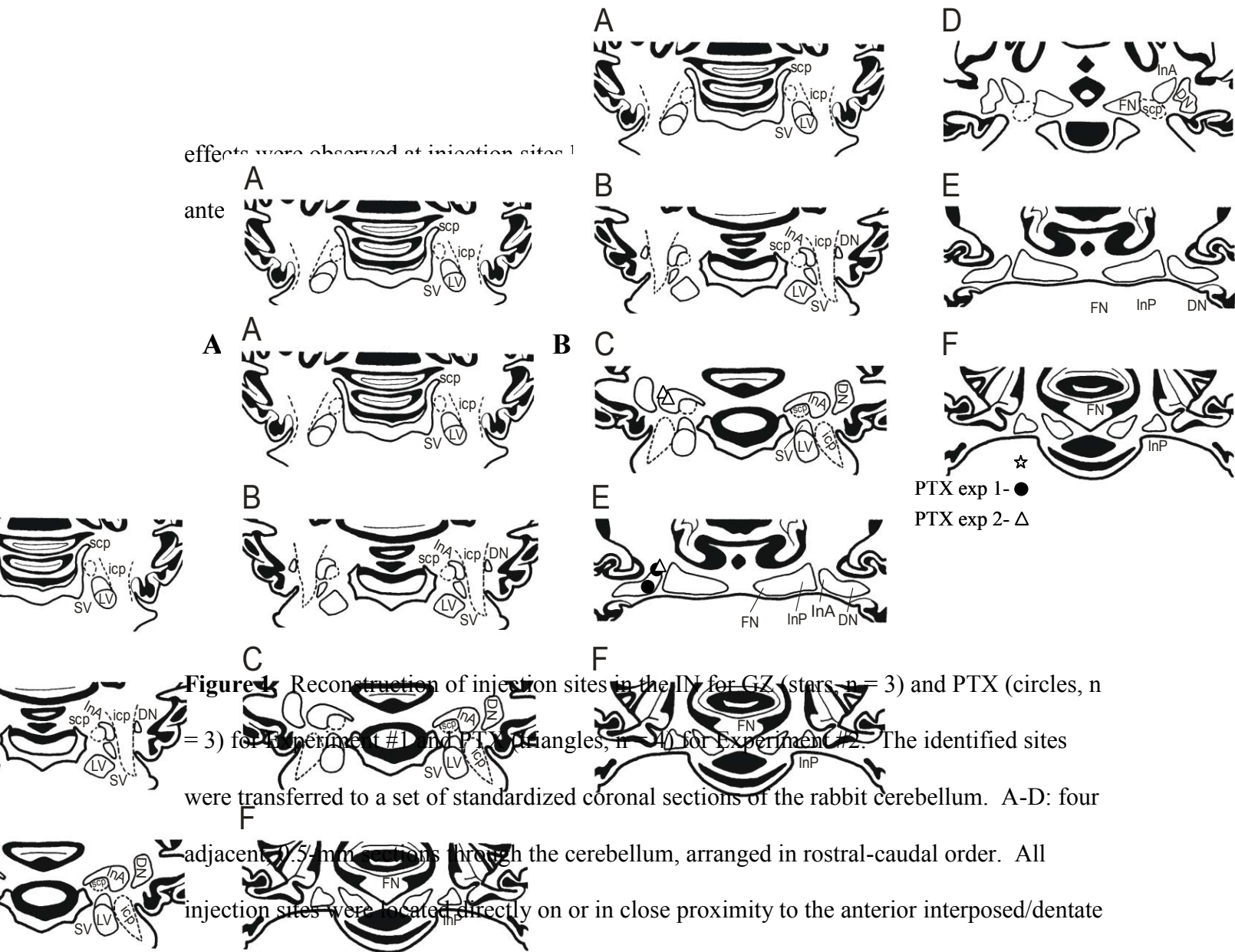

Figure 1. Reconstruction of injection sites in the IN for GZ (stars, n = 3) and PTX (circles, n = 3) for Experiment #1 and PTX (triangles, n = 4) for Experiment #2. The identified sites were transferred to a set of standardized coronal sections of the rabbit cerebellum. A-D: four adjacent 0.5-mm sections through the cerebellum, arranged in rostral-caudal order. All injection sites were located directly on or in close proximity to the anterior interposed/dentate nuclear border. InA, anterior interposed nucleus; DN, dentate nucleus; LV, lateral vestibular nucleus; SV, superior vestibular nucleus; InP, posterior interposed nucleus; FN, fastigial nucleus; scp, superior cerebellar peduncle; icp, inferior cerebellar peduncle.

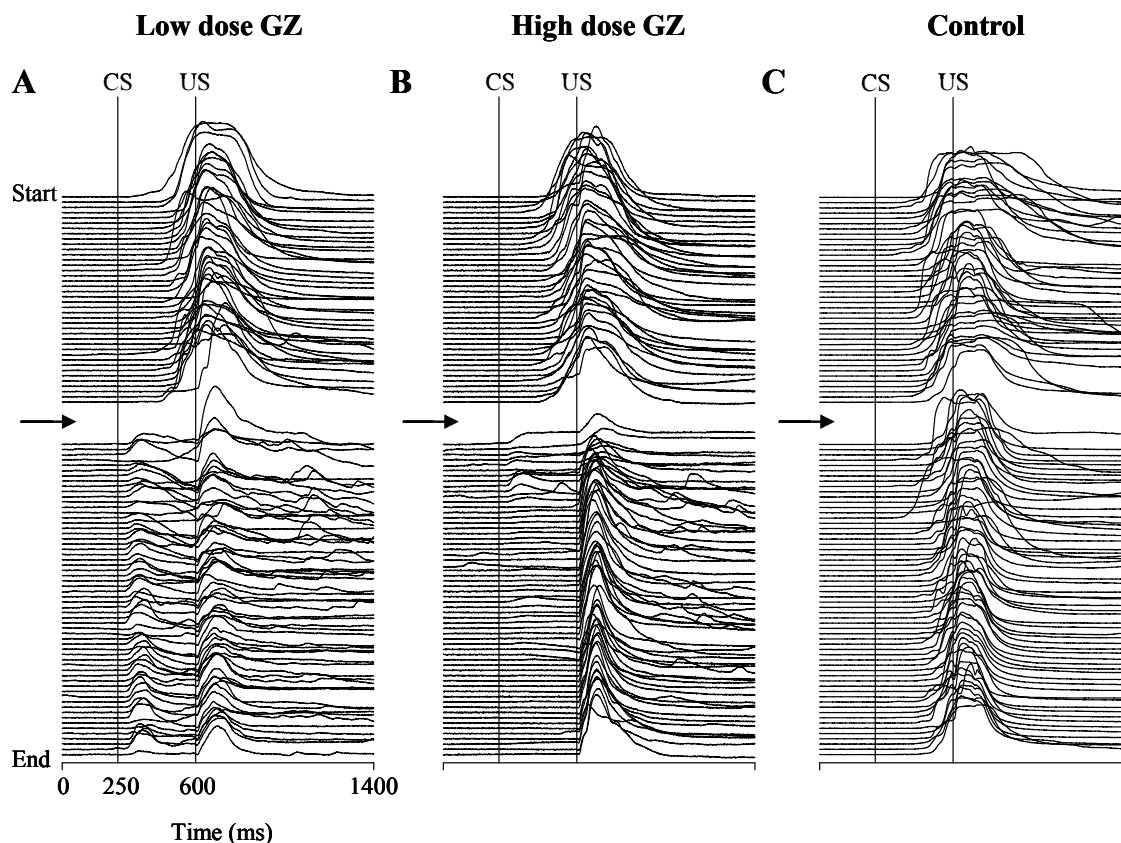

Figure 2. Examples of stack plots of eyeblink mechanograms showing the effects of GZ on conditioned eyeblink performance when injected in the IN. Each experiment begins at the top with each mechanogram representing 1 trial. All mechanograms were filtered by subtracting the mean pre-stimulation eyelid position in the corresponding trial. A: an experiment with an injection of low-dose GZ. Following the injection (indicated with arrow), the latency of conditioned responses (upward deflections between CS and US onset markers) was shortened for the remaining 60 trials. B: identical to plot A but in this experiment, high-dose GZ was injected. Following the injection, CRs were gradually abolished. C: control for both A and B in which aCSF was injected following 40 pre-injection trials. There was no vehicle effect on the expression of CRs in the experiment.

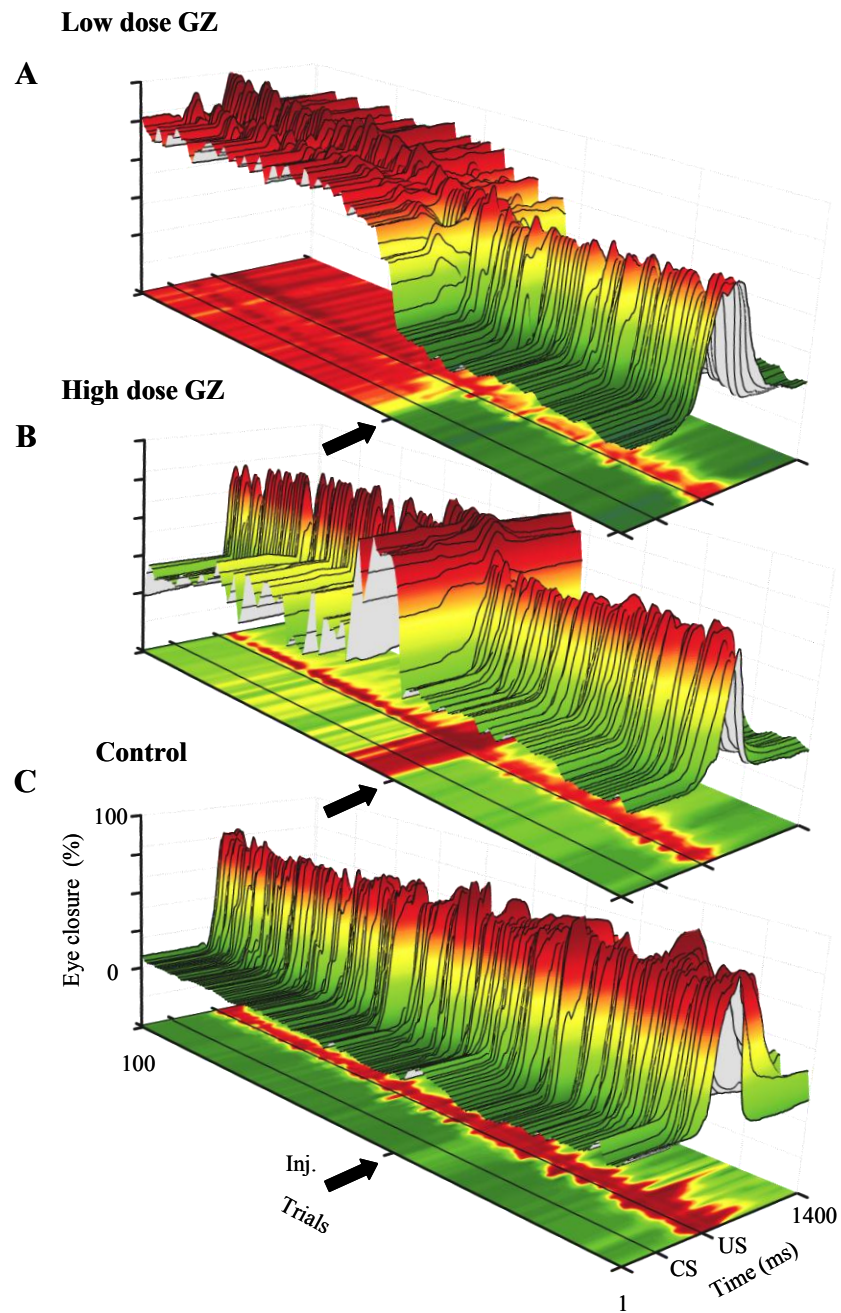

Figure 3. Three dimensional surface plots of the individual examples of eyeblink mechanograms shown in **Fig. 2**. In this display, eyeblink mechanograms were not filtered to

preserve information about the tonic eyelid position. Each cut through the surface plot corresponds to one trial and the colors, together with the z axis, code the eyelid aperture (dark green = open, yellow = intermediate, dark red = mostly closed). A: one hundred trials illustrating the effect of low-dose GZ. The GZ injection (thick arrow) induced a long lasting tonic eyelid closure, coupled with decreased eyeblink amplitude and SLRs. B: effect of high-dose GZ showing SLRs super-imposed on a tonically closed eye. Shortly thereafter, the tonic eyelid closure subsided and CRs were gradually abolished. C: control experiment for both A and B where aCSF, injected after 40 pre-injection trials, had no effect on tonic eyelid closure.

7.3.2 Effects of Gabazine and Picrotoxin on CR expression (Experiment #1)

The effects of both drugs on CR expression were dose-dependent, yielding either SLRs or CR abolition. Drug doses that led to these effects varied between rabbits. For example, a dose that shortened latencies of CRs in one rabbit could abolish CRs in another. Consequently, both the low and high doses were individually titrated for each animal. Our criterion for the high-dose was suppression of CR incidence to 30 % or less in at least one post-injection block of 10 trials. The low-dose was identified based on the appearance of SLRs lasting at least 10 minutes (about 30 trials).

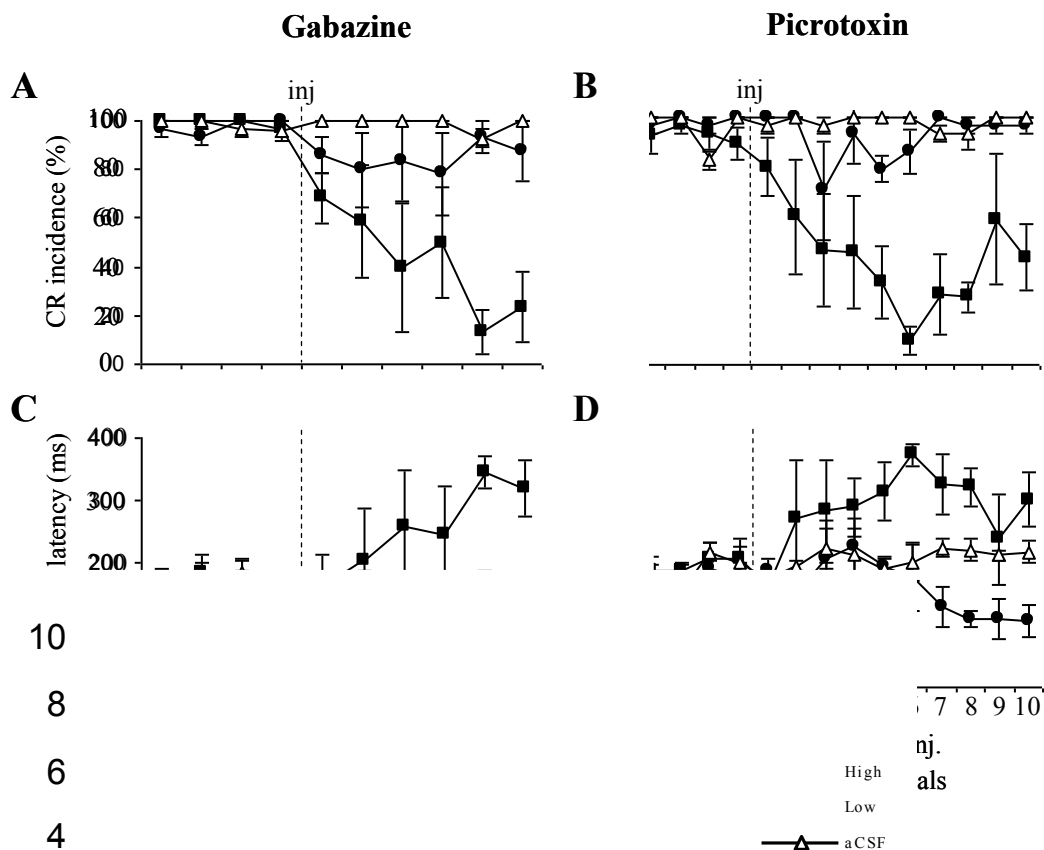

Figure 4. Effects of low (circle) and high doses (squares) of GZ and PTX on means (\pm SE, $n = 3$) for CR incidence and eyeblink latency. A: effect of GZ on CR incidence. While high-dose GZ suppressed CRs, low-dose GZ and control injections of vehicle (triangles) had minor or no effect on CR incidence. B: effect of PTX on CR incidence. Similar to GZ, high-dose PTX suppressed CRs, but CRs had a greater tendency to recover toward the end of the experiment. C: effect of GZ on eyeblink latency. High-dose GZ increased CR latency whereas low-dose decreased the CR onset time. D: effect of PTX on eyeblink latency. Effects of PTX are similar to GZ, except that low-dose PTX took 60 trials to shorten CR latency. In A-D, injections of aCSF (triangles) had no effect on CR expression.

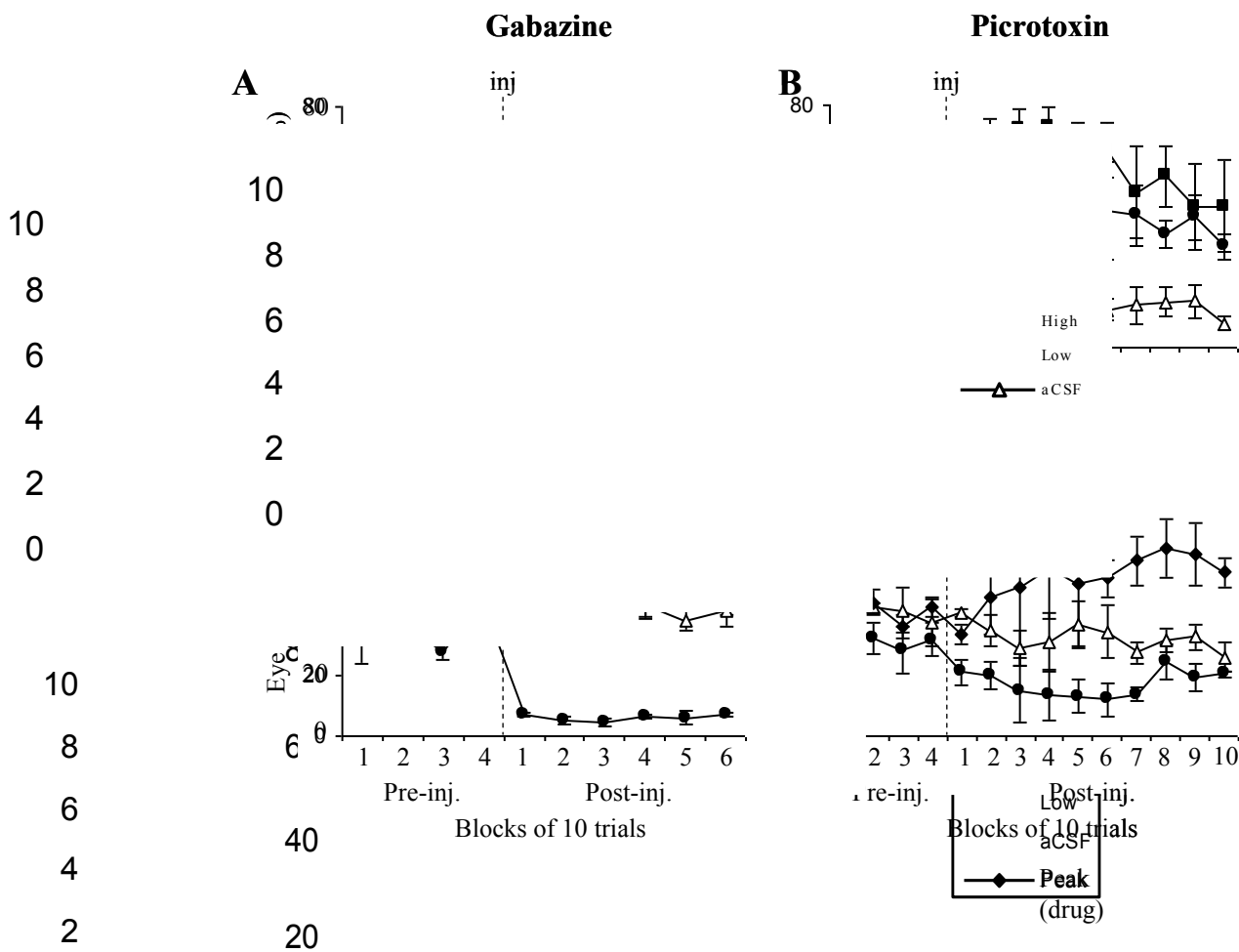

Figure 5. Effects of low (circle) and high-doses (square) of GZ and PTX on the means (\pm SE, $n = 3$) for eyeblink baseline, peak, and amplitude. A: effect of GZ on eyeblink baseline expressed in percentage of maximum eyelid closure. Low-dose GZ produced an immediate and long lasting eyelid closure. The eyelid closure resulting from high-dose GZ was short-lasting and it recovered within 20 trials. B: effect of PTX on eyeblink baseline. Both low and high-dose PTX induced long lasting eyelid closure. Control injections of aCSF (triangles) in A and B did not affect eyeblink baseline. C: effect of a low, SLR-inducing dose of GZ on eyeblink peak (diamonds) and amplitude (circles). Injected (inj.) after 40 pre-

injection trials, GZ immediately increased eyeblink peak and decreased amplitude. D: effect of SLR-inducing, low-dose PTX on eyeblink peak and amplitude. Similar to GZ, PTX increased CR peaks but decreased eyeblink amplitudes.

7.3.3 Low-Dose Effects

When compared to control aCSF injections (**Fig. 2C**), low-dose GZ injections (0.13 – 0.51 nmol) significantly shortened CR latencies (**Figs. 2A, 3A**, $F_{1,2} = 29.91$, $p = 0.032$). The mean pre-injection eyeblink latency was 155.72 ± 15.03 ms and it declined immediately to 96.89 ± 15.80 ms in the first post-injection block of trials, peaking in the fifth at 78.41 ± 20.57 ms (**Fig. 4C**). Typically, SLRs were super-imposed on the background of GZ-induced tonic eyelid closure (**Fig. 3A**). Mean pre-injection eyelid aperture was 8.42 ± 1.28 % of maximum eyelid closure. Following GZ, rabbits had a tendency to ‘squint,’ significantly reducing their mean pre-eyeblink eyelid aperture nearly 6-fold to 56.69 ± 3.87 (**Fig. 5A**, $F_{9,18} = 6.97$, $p = 0.00025$). In parallel to changes in eyeblink latency, GZ significantly reduced CR amplitude measured relative to eyelid aperture before the eyeblink (**Figs. 2A, 3A, 5C**, $F_{9,18} = 2.96$, $p = 0.024$). However, since these small amplitude CRs were executed on the background of a partially closed eye, the CR peak (measured relative to maximally opened eyelids) actually increased following the injection. Control injections of aCSF had no effect on CR latencies, amplitudes, or on baseline eyelid aperture (**Figs. 4C, 5A, 5C**).

Similar to GZ, injections of low-dose PTX (0.31 – 4.98 nmol) shortened eyeblink latency. However, this effect was notably delayed when compared to GZ and it developed only in the last four blocks of the 10-block post-injection period (**Fig. 4D**, $F_{13,26} = 3.48$, $p =$

0.0032). This difference in the effect onset was most likely related to differences in effectiveness of drug diffusion. Mean eyeblink latency decreased from 177.95 ± 9.53 ms pre-injection to 104.41 ± 25.79 ms by post-injection block 10. Also similar to GZ, PTX increased tonic eyelid closure (**Fig. 5B**, $F_{13,26} = 2.13$, $p = 0.049$) and it reduced CR amplitude (**Fig. 5D**, $F_{13,52} = 4.09$, $p = 0.00013$) while increasing the absolute eyeblink peak in the CS - US period. Low doses of GZ and PTX had only a moderate effect on CR incidence, being slightly reduced and tending to recover toward the end of experiments (**Figs. 4A-B**).

7.3.4 High-Dose Effects

Effects of high doses of GZ (0.51 – 1.02 nmol) and PTX (0.62 – 7.47 nmol) were remarkably different from low-dose injections of these drugs. Most notably, both GZ and PTX at high doses suppressed CRs. An individual example in **Figs. 2B** and **3B** shows that shortly after the injection of GZ, CRs were abolished, contrasting with the CR latency-shortening effects of low-dose GZ in the same animal and injection site (**Figs. 2A, 3A**).

At the group level, high doses of GZ and PTX gradually, but significantly suppressed CR incidence (**Figs. 4A-B**) when compared to the pre-injection performance and to the control experiment (GZ: $F_{9,18} = 9.21$, $p = 0.00004$, PTX: $F_{13,26} = 5.25$, $p = 0.0002$). This gradual suppression of CRs was paralleled by a gradual increase of eyeblink latency in the CS - US period (**Figs. 4C-D**, GZ: $F_{9,18} = 4.29$, $p = 0.0041$, PTX: $F_{13,26} = 5.23$, $p = 0.00017$). While the effect of high-dose GZ on tonic eyelid closure was transient (**Fig. 5A**), high-dose PTX produced sustained eyelid closure, nearly doubling from 21.25 ± 3.40 % pre-injection to 41.42 ± 4.78 % of the full eyelid closure post-injection (**Fig. 5B**, $F_{13,26} = 0.64$, $p = 0.000031$).

7.3.5 Effects of Low-Dose Picrotoxin on CR and UR expression (Experiment #2)

In Experiment #1, we demonstrated how low doses of PTX affected CR expression. In considering whether disinhibiting the IN affects URs, four rabbits were injected with an SLR-eliciting dose of PTX so parallel effects of this treatment on CR and UR expression could be examined. In these animals, paired CS + US trials were intermixed with three different types of US trials: light, weak airpuff, and regular airpuff. As expected, injections of low-dose PTX (2.49 to 6.22 nmol) shortened CR latencies (**Fig. 6A**). The repeated-measures ANOVA revealed a significant drug and block-of-trials interaction (**Fig. 7A**, $F_{3,9} = 8.061$, $p = 0.0064$). Low-dose PTX shortened baseline CR latency from 197.20 ± 20.85 ms pre-injection to 99.43 ± 13.53 ms in the third block of post-injection trials. The tonic eyelid closure increased from 5.36 ± 0.76 % pre-injection to 20.02 ± 3.42 % in the second post-injection block and to 27.53 ± 8.26 % in the third ($F_{3,9} = 4.23$, $p = 0.04$). In parallel with tonic eyelid closure, the CR peak increased from 32.70 ± 7.41 % in pre-injection trials to 59.05 ± 12.04 % in the third post-injection block (**Fig. 8B**). This CR peak finding was revealed as main effects for the within-subject factor, blocks ($F_{3,9} = 4.70$, $p = 0.031$), and for the between-subject factor, PTX vs aCSF ($F_{3,9} = 11.81$, $p = 0.041$). Injections of vehicle had no effect on CR latency or tonic eyelid position. Since CR amplitudes were not significantly affected by PTX (**Fig. 8A**), it is likely that changes in the CR peak amplitude were due to increased tonic eyelid closure.

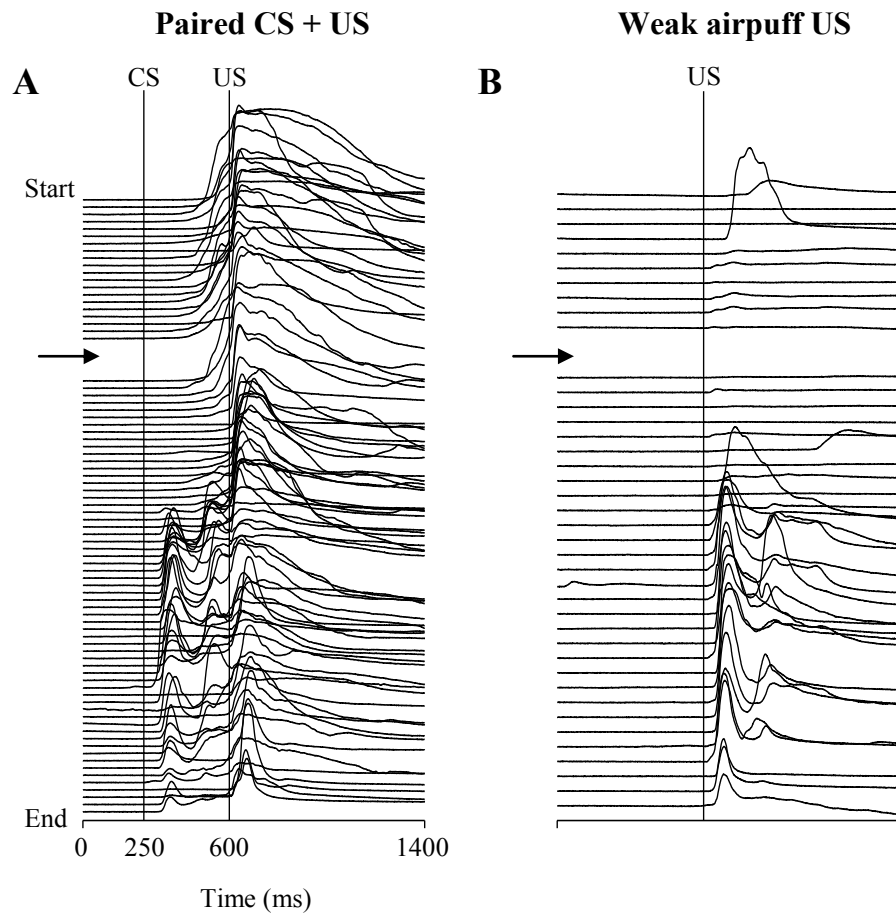

Figure 6. Example of effects of PTX injections in the IN on the performance of conditioned eyeblinks and on unconditioned responses evoked by weak airpuffs. Both stack plots of eyeblink mechanograms are a complete printout from the same experiment. The experiment begins at the top, with each trace representing one trial, and the time of injection is indicated by an arrow. A: in paired CS + US trials, PTX shortened the latency of CRs (positive trace deflections between the CS and US markers). B: in weak airpuff-alone trials, PTX increased UR amplitude approximately at the same time when SLRs were observed in A.

7.3.6 URs to the weak airpuff

Among the three types of URs tested, eyeblinks to the weak airpuff were the most affected. Most notably, PTX increased UR amplitude during the same time period in which the drug affected CR expression (**Figs. 6A-B**). The mean amplitude of URs to the weak airpuff increased from 9.01 ± 2.65 % pre-injection to 45.88 ± 4.48 % during the third block of post-injection trials (**Fig. 8C**, $F_{3,9} = 10.75$, $p = 0.00025$). Mean UR peaks to the weak airpuff likewise increased from 13.66 ± 2.42 % during the pre-injection block of 10 trials to 67.64 ± 8.45 % during the third block of post-injection trials (**Fig. 8D**, $F_{3,9} = 11.18$, $p = 0.0022$). Similar to the PTX effect on CR latencies, mean UR latencies to the weak airpuff were shortened 50 % post-injection (**Fig. 7B**, $F_{3,9} = 5.095$, $p = 0.025$), steadily decreasing from 68.43 ± 9.80 % pre-injection to 33.80 ± 1.91 % in the third block of post-injection trials. Control injections of vehicle had no effect on latency or amplitude of URs to the weak airpuff (**Fig. 7B, 8C**).

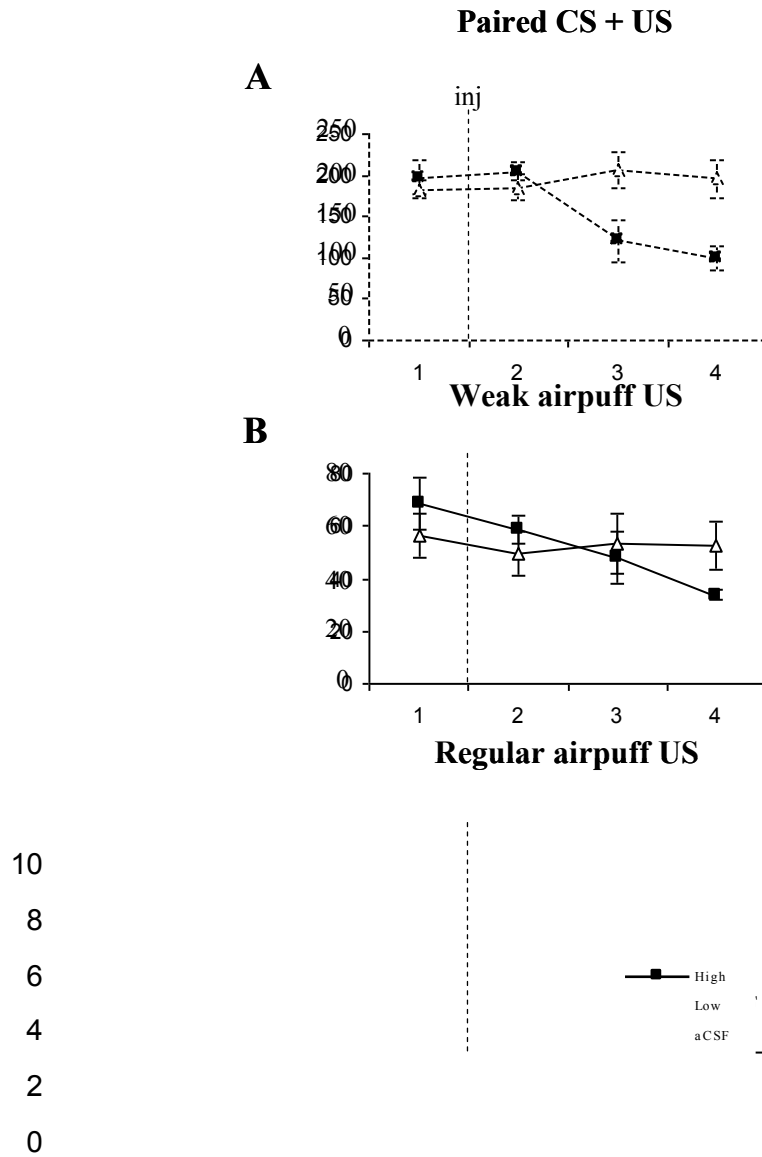

Figure 7. Effects of PTX (squares) injections (inj.) on the means (\pm SE, $n = 4$) for CR and UR latency. A: effect of PTX on eyeblink latency in paired CS + US trials. PTX reduced CR latency. B: effect of PTX injections to the IN on UR latency during weak airpuff trials. The UR latency gradually decreased when compared to the pre-injection level. C: PTX had

no effect on UR latency during regular intensity airpuff trials. Injections of aCSF (triangles) had no effect on eyeblink latency during either type of trial.

7.3.7 URs to the strong airpuff and to the light

While PTX did not significantly affect UR amplitude to the strong airpuff (**Fig. 8E**), the profile and peak of these eyeblinks were affected. The mean peak of URs to the strong airpuff increased from 54.33 ± 11.74 % pre-injection to 91.34 ± 3.84 % during the third block of post-injection trials. (**Fig. 8F**, $F_{3,9} = 5.61$, $p = 0.019$). The maximum instantaneous velocity of eyelid closure during eyeblinks to the strong airpuff nearly doubled from 0.99 ± 0.26 % per ms pre-injection to 1.93 ± 0.23 % per ms during the third block of post-injection trials (**Fig. 9D**, $F_{3,9} = 4.49$, $p = 0.035$). Besides its effect on eyelid closure velocity, PTX also delayed eye re-opening which was manifested as greater eyelid closure still present at the end of the 1400-ms recording period. Delayed eye re-opening was apparent both in raw and normalized eyeblink averages (**Figs. 9A, 9C**). At the end of the 1400 ms recording period, raw eyeblinks had increased from 9.44 ± 1.30 % in pre-injection to 53.28 ± 12.76 % during the third block of post-injection trials (**Fig. 9A**, $F_{3,9} = 9.65$, $p = 0.00036$). Normalized responses showed the same tendency (**Fig. 9C**). Injections of vehicle had no effect on the peak, profile, or velocity of URs to the strong airpuff (**Figs. 8E-F, 9B**). Furthermore, PTX did not significantly affect URs to light.

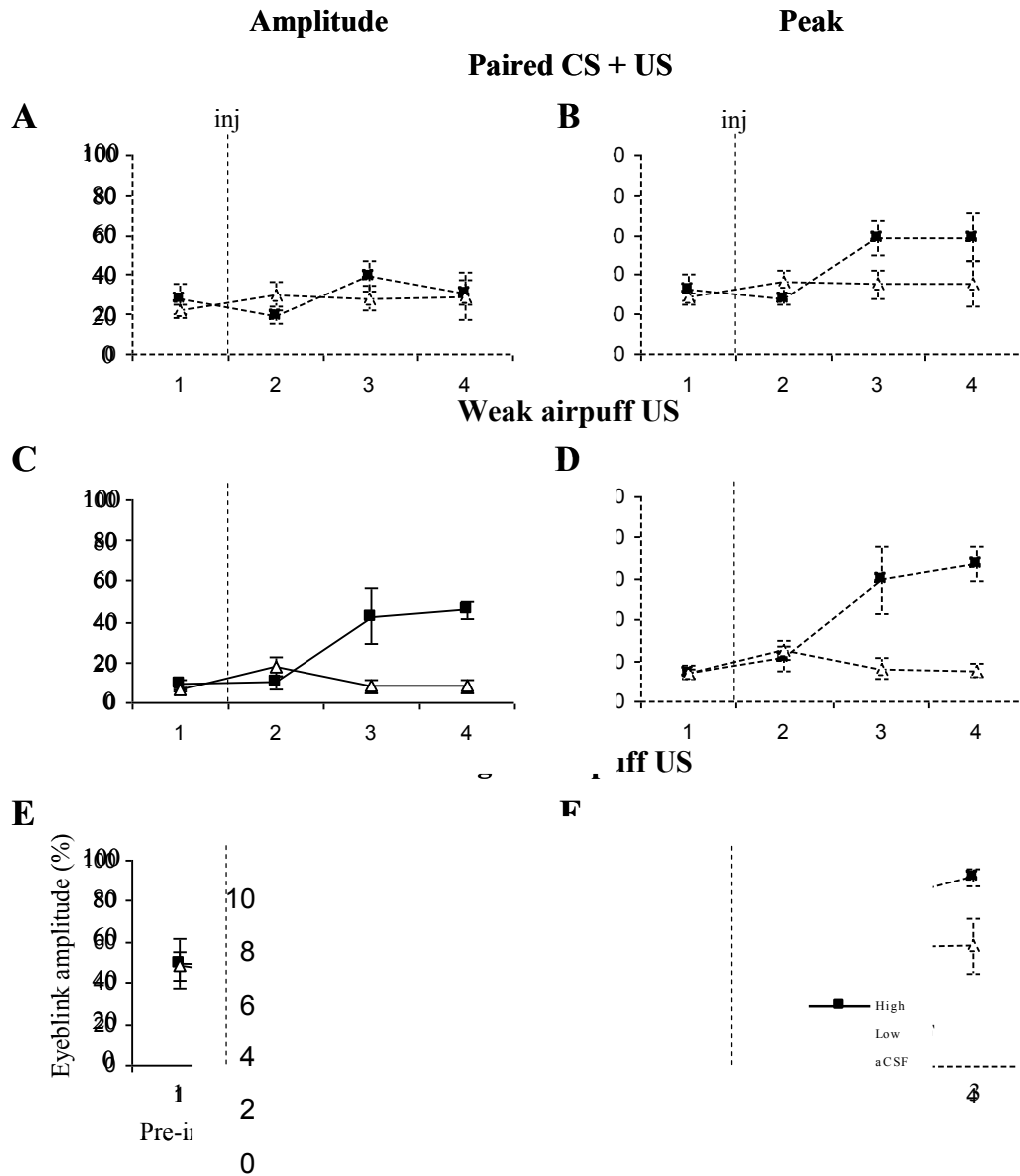

Figure 8. Effects of PTX (squares) on the means (\pm SE, $n = 4$) of amplitudes (left column) and peaks (right column) of CRs and airpuff-evoked URs. A: PTX injections (inj.) did not significantly affect CR amplitude in CS + US trials. B: PTX injections increased the CR peak in CS + US trials. C: the amplitude of responses to the weak airpuff US increased following PTX injections. D: the peak of responses to the weak airpuff US also increased

following PTX injections. E: the amplitude of regular airpuff-evoked URs was not affected by PTX. F: the peak of regular airpuff URs slightly increased following PTX. Neither peaks nor amplitudes of responses in all three conditions were affected by control injections of aCSF (A-F).

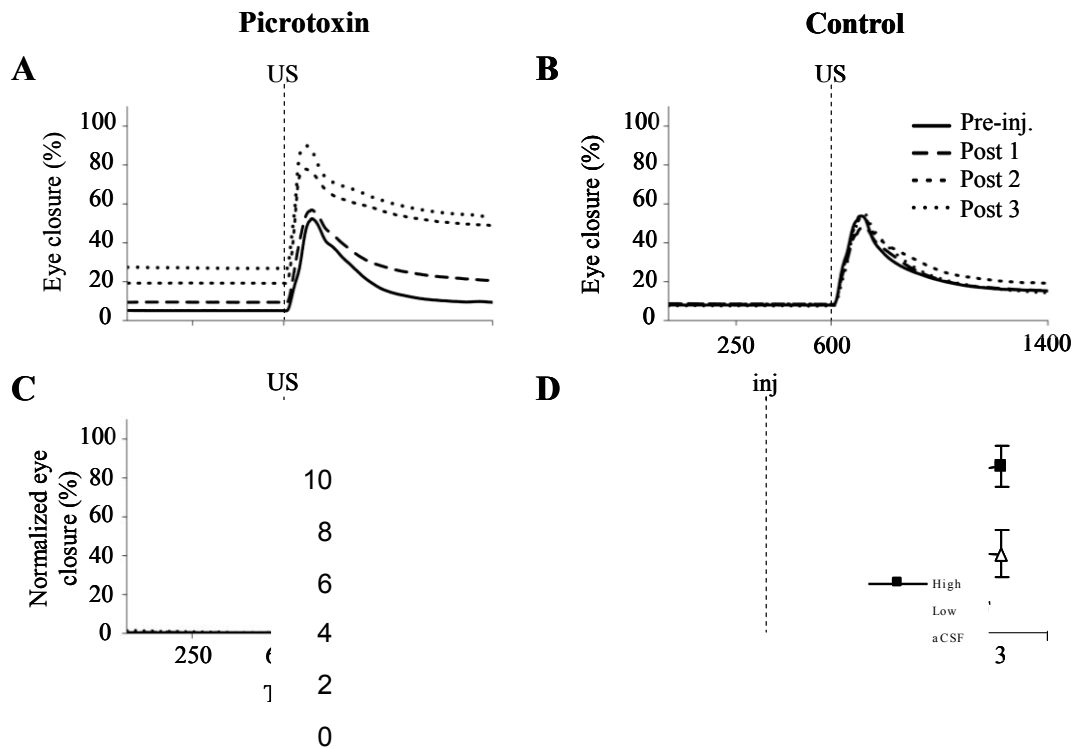

Figure 9. Effects of PTX on the profile and instantaneous velocity of URs evoked by strong airpuff. A: average eyeblinks ($n = 4$) to the strong airpuff in one block of trials before (Pre-inj.) and three blocks of trials following (Post 1-3) PTX injections. PTX increased tonic eyelid closure seen as increased signal levels before the US onset. Also, eyelid re-opening was delayed in post-injection trials as indicated by the higher signal at the end of the recording period. C: eyeblinks from (A) were normalized to compare their time profiles.

This analysis revealed a slight decrease in UR peak time as well as a clear delay in post-blink eyelid re-opening in post-injection trials. B: average eyeblinks to the strong airpuff before and after control injections of aCSF. Injections of vehicle had no effect on the shape and velocity of strong airpuff-evoked eyeblinks. D: maximum velocity of URs to the strong airpuff (mean \pm SE, n = 4). PTX significantly increased the maximum instantaneous velocity of strong airpuff URs.

7.4 Discussion

The present study demonstrated that blocking GABA_A neurotransmission in the IN with PTX or GZ affects CRs in a dose-dependent manner. While high doses of GABA_A blockers suppressed CR expression, lower drug doses shortened CR latency. Besides their effects on CRs, the SLR-inducing doses of PTX also affected non-associative components of eyelid movements; they increased tonic eyelid closure and facilitated URs evoked by trigeminal stimulation.

7.4.1 Effects on CR expression

We hypothesized that prior variance in results of blocking GABA_A receptor-mediated neurotransmission in the IN on CR expression could be related to the extent of the GABA_A block. Our data presented here confirm this notion. High amounts of PTX and GZ suppressed CRs. This finding confirmed previous reports of CR abolition (Mamounas et al., 1987; Attwell et al., 2002; Aksenov et al., 2004). On the other hand, lower amounts of both drugs, when administered at sites where high doses abolished CRs, had a minor effect on CR incidence, but significantly shortened their latency. This supports previous reports of SLRs

induced by cerebellar nuclear injections of PTX (Garcia and Mauk, 1998; Medina et al., 2001) or GZ (Ohyama et al., 2006). Furthermore, the amount of PTX and GZ required to produce SLRs varied among individual animals. Although all injection sites in this study were located in the IN region (**Fig. 1**), and their proximity to eyeblink-related parts of cerebellar nuclei was functionally confirmed with muscimol injections abolishing CRs, effective doses of GABA_A blockers had to be titrated to optimize effects. In general, smaller amounts of drugs were required for SLRs and CR abolition at sites with the best muscimol effects, suggesting a dependency on the amount of drug diffusing around the eyeblink representation in deep cerebellar nuclei.

Differences between the effects of high and low drug doses could result from drug spreading to the overlying cerebellar cortex. Blocking GABA_A neurotransmission in the cerebellar cortex increases the tonic firing rate of GABAergic Purkinje cells (Thomsen et al., 2004). Assuming the high drug dose did diffuse into the non-targeted cerebellar cortex, increased Purkinje cell activity would inhibit the IN and abolish CRs. However, this effect would be prevented by the simultaneous suppression of GABA_A neurotransmission in the targeted deep cerebellar nuclei. Thus, conjectured drug diffusion to the cerebellar cortex does not explain CR abolition by high doses of GABA_A blockers.

In agreement with previous reports (Medina et al., 2001), SLR-inducing doses of both blockers reduced CR latency and changed the temporal profile of CRs, which frequently peaked before the US onset (**Figs. 2A, 3A**). GZ reduced CR amplitude (**Figs. 2, 5**) when measured relative to the eyelid position before application of the CS. Effects of PTX on CR amplitude were less pronounced, ranging from a small decrease in Experiment #1 (**Fig. 5**) to

no change in Experiment #2 (**Fig. 8**). On the other hand, CR peaks measured relative to the maximally open eye, increased following both drugs and in both experiments (**Figs. 5, 8**). These seemingly contradictory effects were due to a drug-induced tonic eyelid closure. Following drug injections, CRs were evoked on a background of tonic eyelid closure and the same or smaller blinks resulted in absolute eyelid closure larger than baseline blinks recorded before injections or those recorded after control.

7.4.2 Effects on non-associative components of blinking

High and low doses of PTX and low-dose GZ elicited sustained tonic eyelid closure during which animals maintained partially closed eyelids both during and between trials. This finding confirms and extends our previous reports of PTX effects on tonic eyelid position in instrumental and classical conditioning tasks in the rabbit (Bracha et al., 2001; Aksenov et al., 2004). In our study of instrumental eyelid behavior we found that inactivating the IN with the GABA_A agonist, muscimol, disrupts instrumentally conditioned tonic eyelid closure (Bracha et al., 2001). Since down-regulating the neuronal firing rate in the IN with muscimol produces tonic eyelid opening, whereas increasing the IN neuronal activity with GABA_A antagonists increases tonic eyelid closure, it appears that tonic IN activity controls tonic eyelid aperture. In this regard, it was surprising that high doses of GZ produced only transient tonic eyelid closure, followed by eyelid opening at later stages of the experiment. Pertinent to this finding, in earlier work we observed that injecting the IN with the GABA_A antagonist bicuculline at low concentrations increased the tonic activity of IN neurons and at high concentrations evoked bursting followed by long periods of inactivity (Bayev and Bracha, unpublished observations). If GZ has similar properties, then low doses

would increase the tonic activity of IN neurons (Chen and Evinger, 2006) and enhance tonic eyelid closure. On the other hand, high doses would reduce the IN spontaneous firing rate, leading to eyelid opening and CR abolition.

To determine whether SLR-inducing doses of PTX affect URs, rabbits were presented with trigeminal and visual stimuli. Analyses of latencies, amplitudes, and velocity profiles showed no effect on photic URs. In contrast, PTX facilitated URs evoked by airpuffs. This was most pronounced in weak airpuff trials, where PTX shortened UR latencies and increased UR amplitudes. In strong airpuff trials, PTX increased the maximum instantaneous velocity of eyelid closure and delayed eyelid re-opening following the blink. These findings corroborate observations of GZ effects on URs in anesthetized rats (Chen and Evinger, 2006) and complement reports of opposite effects of IN lesions and inactivations in the rabbit (Welsh and Harvey, 1989; Welsh, 1992; Bracha et al., 1994). Here we have shown that SLR-inducing levels of GABA_A neurotransmission affect non-associative eyelid movements. These data collectively demonstrate IN involvement in the control of tonic eyelid closure and trigeminal stimulation-evoked URs.

7.4.3 Implications for cerebellar control of eyeblinks

The present findings illuminate the controversy about PTX's effect on CR expression (Garcia and Mauk, 1998; Attwell et al., 2002). We have shown that blocking GABA_A neurotransmission affects CRs in a dose-dependent manner. Blocking either GABA_A receptors or chloride channels with low drug doses induces SLRs. On the other hand, administering higher drug doses at the same injection sites abolishes CRs. In their original reports, Mauk and colleagues suggested that SLRs are evoked when GABAergic Purkinje

cells are functionally disconnected from eyeblink representation in the deep cerebellar nuclei (Garcia and Mauk, 1998; Medina et al., 2001). Our results do not support this notion. We propose that during SLRs, cerebellar cortical projections are not disconnected completely because increasing the drug dose further aggravates behavioral effects, resulting in CR abolition.

An important contribution of the present study is showing that SLR-inducing injections of PTX affect non-associative components of blinking. This confirms previous suggestions that the intermediate cerebellum controls both classically conditioned and unconditioned eyeblink reflexes (Welsh and Harvey, 1989; Bloedel and Bracha, 1995; Delgado-Garcia and Gruart, 2006; Chen and Evinger, 2006). It is known that neurons in the interposed nuclei respond to both the tone CS and trigeminal US (Berthier and Moore, 1990; Aksenov et al., 2004; Jimenez-Diaz et al., 2004; Chen and Evinger, 2006). Consequently, it is possible that effects of PTX and GZ could be related to changes of IN task-related signals. However, the effects of IN pharmacological manipulations are also very likely related to changes in tonic IN activity. It is paramount to note that PTX and GZ dramatically enhance the spontaneous firing rate of IN neurons (Aksenov et al., 2004; Chen and Evinger, 2006). These IN neurons then send excitatory projections to the red nucleus and other mesencephalic eyeblink-related targets. In addition, neurons in the red nucleus receive CS and US information (Desmond and Moore, 1991) and project to sensory trigeminal (Davis and Dostrovsky, 1986; Godefroy et al., 1998) and facial nuclei (Holstege and Tan, 1988). Thus, it is possible that the elevated spontaneous IN activity increases excitability of extra-cerebellar eyeblink pre-motoneurons and this could affect CR and UR performance in a

manner unrelated to learning. Since PTX and GZ affect both neuronal modulation and spontaneous activity simultaneously, dissociating contributions of these two processes to CR and UR performance is difficult and the present study cannot resolve this question (for review, see Bracha et al., 2008).

The most plausible explanation of the effects of low doses of PTX and GZ is that they partially block the inhibitory drive of Purkinje cells and IN GABAergic interneurons. This enhances the spontaneous firing rate of IN neurons, and reduces their depth of modulation (Aksenov et al., 2004; Chen and Evinger, 2006). The elevated IN firing in turn increases the activity of eyeblink pre-motoneurons and motoneurons, and modulates transmission of sensory information in the sensory trigeminal system. The high spontaneous firing within eyeblink circuits enhances tonic eyelid closure. Importantly, this tonic effect on eyelid position is context-dependent, because removing the animal from the restraining box restores normal eyelid aperture. This suggests a so far unknown and context-dependent gating mechanism that can cancel the influence of the high IN firing rate on pre-motoneurons. The reduced modulation of IN neurons is transmitted to mesencephalic pre-motoneurons, which themselves are now more excitable and respond more vigorously to IN signals as well as to direct CS and US inputs. The collective changes both inside and outside of the cerebellum are then responsible for facilitating responses to the CS and trigeminal US. Notably, the described facilitation of eyeblink circuits does not affect optic URs. This indicates that CR / UR facilitation is not due to increased excitability of motoneurons, because this process would affect blinks to all modalities.

In our previous study we have shown that large doses of PTX dramatically increase IN firing rates and suppress neuronal responses to the CS and US (Aksenov et al., 2004). It is likely that this over-excitation of IN neurons, together with the associated high excitability in their efferent targets, saturate the circuit's capacity to respond to the CS and this suppresses CRs on the background of pronounced eyelid closure. As addressed above, the mechanism of high GZ doses is different – it appears to suppress IN activity. The resulting suppression of cerebellar task-related signals and the decreased excitatory drive to eyeblink pre-motoneurons counter-balance tonic eyelid closure and suppresses CRs.

7.5 Material and Methods

7.5.1 Subjects

The experiments were performed on 10 male New Zealand White Rabbits (Harlan; Indianapolis, IN) weighing 2.5-3.0 kg (3-4 months old at time of surgery). Rabbits were housed individually on a 12-hour light/dark cycle and provided food and water *ad libitum*. All experiments were performed in accordance with the National Institutes of Health's "Principles of Laboratory Animal Care" (publication No. 86-23, revised 1985), the American Physiological Society's "Guiding Principles in the Care and Use of Animals," and the protocol approved by Iowa State University's Committee on Animal Care.

7.5.2 Surgery

Using aseptic techniques, surgery was performed on naive rabbits anesthetized with a mixture of ketamine (50 mg/kg), xylazine (6 mg/kg) and acepromazine (1.5 mg/kg). The head was secured in a stereotaxic apparatus with lambda positioned 1.5 mm ventral to bregma. A stainless steel injection guide tube (28-gauge thin-wall tubing) was

stereotaxically implanted 0.5 mm dorsal to the expected location of the left anterior IN (($0.69x + 4.8$) - x mm rostral from lambda, x being the horizontal distance between bregma and lambda in mm: 5.3 mm lateral and 13.5 mm ventral to lambda). A 33-gauge stainless steel stylet was inserted into the guide tube in-between experiments to protect its patency. The guide tube, anchor screws, and a small Delrin block designed to accommodate an airpuff delivery nozzle and eyeblink sensor were secured in place with dental acrylic. All animals were treated with antibiotics for 5 days during recovery from surgery.

7.5.3 Training procedures

Following recovery from surgery, rabbits were adapted to a restraint box in three daily 30-minute sessions. Adapted rabbits were trained in the standard classical conditioning paradigm until they reached at least 90 % CRs for 3 consecutive days. The conditioned stimulus (CS) was an 85-db, 450-ms, 1-kHz tone, super-imposed on a continuous 70-db white noise background. The CS co-terminated with a 40-psi, 100-ms airpuff unconditioned stimulus (US) directed to the left eye. The inter-stimulus interval was 350 ms and each training session consisted of 100 trials presented in pseudorandom, 15-25 sec inter-trial intervals. All experiments were conducted in a sound-attenuated chamber.

Animals tested in the UR performance experiments (Experiment #2) were adapted to a mixed paradigm following training. The paired presentation of the CS + US was alternated with three different types of US in Experiment #2: a normal airpuff US, a weak airpuff US (100 ms, 4-5 psi at the source), and a photic US (30 ms flash of four white LEDs positioned in front of the left eye; light intensity was dimmed to only elicit near-threshold URs). This

mixed-stimulation paradigm consisted of repeated blocks of 10 trials: 4 paired CS + US, 2 normal US, 2 weak airpuff US, and 2 light US trials were pseudorandomly intermixed.

7.5.4 Injection procedures

Injections were delivered via a 33-gauge stainless steel injection needle which was connected via transparent Tygon tubing to a 10- μ L Hamilton syringe. The injection tubing was first filled with nanopure water, and then a small bubble was drawn into the end of the injection needle before drawing in drug. The bubble was used for monitoring the injected volume relative to gradation marks on the tubing. The injection needle was inserted in the guide tube prior to beginning the experiment. A pre-injection period of 40 trials (or 50 trials in Experiment #2) was presented to rule out needle insertion effects and to assess baseline eyeblink performance. Following the pre-injection period, drug micro-injections were manually administered at a rate of 0.5 μ L/min. To assess the drug effect, training continued for 60-150 additional trials.

The present study had two objectives. In the first group of rabbits ($n = 6$), CR performance was examined following injection of two GABA antagonists, picrotoxin (PTX, chloride channel blocker; Sigma-Aldrich, USA) and gabazine (GZ, GABA_A receptor antagonist; Ascent Scientific, Weston-super-Mare, UK). Of the 6 animals, 3 were used in the PTX group and 3 were used in the GZ group. In preliminary experiments we found that effects of both drugs were dose-dependent besides being animal and injection site-dependent. For this reason, effective injection sites and drug doses in each animal were determined. The starting doses for PTX and GZ were 0.62 nmol and 0.51 nmol, respectively. If CRs were abolished after the injection, this drug concentration was considered the 'high-dose,' and the

drug dose was progressively decreased on consecutive days until SLRs were observed (the ‘low-dose’ for the drug) or until no drug effect was detected. If no effect on CR performance was found following the initial drug injection, the drug dose was progressively increased until SLRs (the ‘low-dose’) and CR abolition (the ‘high-dose’) were detected. Only one drug was injected on any given experimentation day. Both GZ and PTX were dissolved in artificial cerebrospinal fluid and their pH was adjusted to 7.4 ± 0.1 . All injections of PTX and GZ were performed at CR expression-related deep cerebellar nuclear sites where 0.5 μL of muscimol (1.75 nmol) completely suppressed conditioned eyeblinks (Bracha et al., 1994).

In the second group of animals ($n = 4$), the parallel effects of PTX on CR and UR expression were examined (Experiment #2). In this group of rabbits, PTX was injected in 0.5- μL (0.3 nmol) increments beginning immediately following 50 pre-injection trials. These injections were administered every 20 trials until SLRs were observed or until 2.5 μL of PTX had been cumulatively administered. In control experiments for both Experiment #1 and Experiment #2, an equal volume of drug vehicle (aCSF) was injected using the same injection protocol.

7.5.5 Data recording and analysis

Rabbit behavior was monitored using an infrared video system installed in the experiment chamber. Eyelid movements were recorded by a frequency-modulated infrared sensor that measures infrared light reflected from the eye and peri-orbital region (Ryan et al., 2006). The sensor, attached to an aluminum stage, was secured to the Delrin block on the rabbit’s head before every experiment. The output of the sensor was amplified, digitized (25 kHz, 12-bit A/D converter), and stored in a PC-based data acquisition system. During each

trial, 1400 ms of the signal was recorded, beginning with 250 ms of baseline before the CS onset and extending for 800 ms beyond the US onset.

Eyeblink responses from each trial were examined off-line for the presence of CRs within the time window between CS and US onsets and for the presence of URs in US-alone trials. The threshold for eyeblink detection was set to 5 standard deviations of the baseline signal noise, which in the present setup corresponded to an approximately 0.15 mm decrease in eyelid aperture. The following response parameters were measured in each trial: baseline eyelid aperture, response latency, response amplitude and response peak. Response amplitude was defined as the difference between the baseline eyelid aperture and the maximum eyelid closure in the corresponding response time window for each trial. Response peak was calculated as the difference between the experiment-wide maximum eyelid aperture (openness) within every injection experiment (the signal value corresponding to completely open eyelids) and the maximum eyelid closure in the corresponding response time window for each trial. All amplitudes were first measured in A/D units of the recording system. Typical eyeblinks in rabbits consist of eyelid closure and subsequent folding of external eyelids. Both of these response components were detected by our IR sensor (Ryan et al., 2006). The native amplitude measurements were normalized by converting them to a percentage of maximum eyeblink, assuming that the difference between minimum and maximum sensor signals in a particular experiment captures the eye both maximally open and closed. Means of eyeblink measures were calculated for consecutive blocks of 10 trials in Experiment #1. In Experiment #2, means of eyeblink measures were calculated for blocks of trials as follows: 20 paired CS + US, 10 light, 10 weak airpuff, and 10 strong airpuff trials,

which were all randomly presented during blocks of 50 trials. In addition, instantaneous velocities were calculated in a sliding window of 20 msec as the first derivative of rise-to-peak velocities of URs to light and to the strong airpuff in Experiment #2. To compare time profiles of URs to the light and strong airpuff, response averages were normalized by expressing them as a percentage of their amplitude. We tested unique hypotheses about dose dependence by conducting separate repeated measures ANOVAs for PTX and GZ at each dose (high concentration: abolition-inducing, and low concentration: SLR-inducing). Response variables, divided into blocks of 20 trials as the within-subject repeated measures, were modeled against a two-factor treatment (drug vs vehicle) together with subject as a blocking factor. Reported F-ratios and their p-values refer to main effects only when there was no significant interaction between treatment and blocks-of-trials. All group data were reported as mean \pm standard error of mean, and significance was declared by an alpha level = 0.05. All statistical analyses were performed using Statsoft Statistica software.

7.5.6 Histology

Upon the conclusion of experimentation, rabbits were deeply anesthetized with a cocktail of ketamine (100 mg/kg), xylazine (12 mg/kg), and acepromazine (3 mg/kg). Injection sites were marked by injecting 1 μ L of tissue-marking dye. Animals were perfused transcardially with 1 L of a phosphate-buffered saline followed by 1 L of a tissue fixative (10 % buffered formalin). Carefully excised brains were stored in a solution of 30 % sucrose and 10 % formalin and subsequently sectioned coronally at 50 μ m on a freezing microtome. The sections were mounted onto gelatin-coated slides, and once dry, stained with luxol blue and

neutral red. Using bright light microscopy, injection locations were determined and plotted on standard sections of the rabbit cerebellum.

7.6 References

- Aksenov, D., Serdyukova, N., Irwin, K., Bracha, V., 2004. GABA neurotransmission in the cerebellar interposed nuclei: involvement in classically conditioned eyeblinks and neuronal activity. *J. Neurophysiol.* 91, 719-727.
- Attwell, P.J., Ivarsson, M., Millar, L., Yeo, C.H., 2002. Cerebellar mechanisms in eyeblink conditioning. *Ann. N. Y. Acad. Sci.* 978, 79-92.
- Berthier, N.E. and Moore, J.W., 1990. Activity of deep cerebellar nuclear cells during classical conditioning of nictitating membrane extension in rabbits. *Exp. Brain Res.* 83, 44-54.
- Bloedel, J.R. and Bracha, V., 1995. On the cerebellum, cutaneomuscular reflexes, movement control and the elusive engrams of memory. *Behav. Brain Res.* 68, 1-44.
- Bracha, V., Webster, M.L., Winters, N.K., Irwin, K.B., Bloedel, J.R., 1994. Effects of muscimol inactivation of the cerebellar interposed-dentate nuclear complex on the performance of the nictitating membrane response. *Exp. Brain Res.* 100, 453-468.
- Bracha, V., Zbarska, S., Parker, K., Carrel, A., Zenitsky, G., Bloedel, J.R., 2008. The cerebellum and eye-blink conditioning: Learning versus network performance hypotheses. *Neuroscience*, (Epub ahead of print).

- Bracha, V., Zhao, L., Irwin, K., Bloedel, J.R., 2001. Intermediate cerebellum and conditioned eyeblinks. Parallel involvement in eyeblinks and tonic eyelid closure. *Exp Brain Res* 136, 41-49.
- Chen, F.P. and Evinger, C., 2006. Cerebellar modulation of trigeminal reflex blinks: Interpositus neurons. *J. Neurosci.* 26, 10569-10576.
- Davis, K.D. and Dostrovsky, J.O., 1986. Modulatory influences of red nucleus stimulation on the somatosensory responses of cat trigeminal subnucleus oralis neurons. *Exp. Neurol.* 91, 80-101.
- Delgado-Garcia, J.M. and Gruart, A., 2006. Building new motor responses: eyelid conditioning revisited. *Trends Neurosci.* 29, 330-338.
- Desmond, J.E. and Moore, J.W., 1991. Single-unit activity in red nucleus during the classically conditioned rabbit nictitating membrane response. *Neurosci. Res.* 10, 260-279.
- Garcia, K.S. and Mauk, M.D., 1998. Pharmacological analysis of cerebellar contributions to the timing and expression of conditioned eyelid responses. *Neuropharmacology* 37, 471-480.
- Godefroy, J.N., Thiesson, D., Pollin, B., Rokyta, R., Azerad, J., 1998. Reciprocal connections between the red nucleus and the trigeminal nuclei: a retrograde and anterograde tracing study. *Physiol Res.* 47, 489-500.

- Holstege, G. and Tan, J., 1988. Projections from the red nucleus and surrounding areas to the brainstem and spinal cord in the cat. An HRP and autoradiographical tracing study. *Behav. Brain Res.* 28, 33-57.
- Ito, M., *The Cerebellum and Neural Control*, Raven Press, New York, 1984.
- Jimenez-Diaz, L., Navarro-Lopez, J.D., Gruart, A., Delgado-Garcia, J.M., 2004. Role of cerebellar interpositus nucleus in the genesis and control of reflex and conditioned eyelid responses. *J Neurosci.* 24, 9138-9145.
- Krupa, D.J., Thompson, J.K., Thompson, R.F., 1993. Localization of a memory trace in the mammalian brain. *Science* 260, 989-991.
- Mamounas, L.A., Thompson, R.F., Madden, J., 1987. Cerebellar GABAergic processes: evidence for critical involvement in a form of simple associative learning in the rabbit. *Proc Natl Acad Sci USA* 84, 2101-2105.
- Medina, J.F., Garcia, K.S., Mauk, M.D., 2001. A mechanism for savings in the cerebellum. *J. Neurosci.* 21, 4081-4089.
- Ohyama, T., Nores, W.L., Medina, J.F., Riusech, F.A., Mauk, M.D., 2006. Learning-induced plasticity in deep cerebellar nucleus. *J. Neurosci.* 26, 12656-12663.
- Ryan, S.B., Detweiler, K.L., Holland, K.H., Hord, M.A., Bracha, V., 2006. A long-range, wide field-of-view infrared eyeblink detector. *J Neurosci. Methods* 152, 74-82.

- Thomsen, K., Offenhauser, N., Lauritzen, M., 2004. Principal neuron spiking: neither necessary nor sufficient for cerebral blood flow in rat cerebellum. *J Physiol* 560, 181-189.
- Welsh, J.P., 1992. Changes in the motor pattern of learned and unlearned responses following cerebellar lesions: a kinematic analysis of the nictitating membrane reflex. *Neuroscience* 47, 1-19.
- Welsh, J.P. and Harvey, J.A., 1989. Cerebellar lesions and the nictitating membrane reflex: performance deficits of the conditioned and unconditioned response. *J. Neurosci.* 9, 299-311.
- Zbarska, S., Bloedel, J.R., Bracha, V., 2008. Cerebellar dysfunction explains the extinction-like abolition of conditioned eyeblinks after NBQX injections in the inferior olive. *J. Neurosci.* 28, 10-20.

CHAPTER 8: CONCLUSIONS AND FUTURE DIRECTIONS

8.1 Study conclusions

The research described in this dissertation addressed the fundamental question of the neurophysiological substrates of motor learning using a popular model of classical eyeblink conditioning. Conceptually, we approached this subject using our concept that views the eyeblink conditioning circuits as a recurrent neuronal network in which spontaneous activity-mediated tonic interactions play an important role in setting the network's optimal functional state (see Chapter 5).

Our research focused first on analyzing the role of GABA-ergic projections in the IN on the expression of conditioned and unconditioned eyeblinks because previous studies that blocked these cortical projections generated controversial results. We discovered that this intervention is drug dose-dependent and thus ascribable to the level of tonic activation of neurons in the IN (Chapter 7). Our work in this area has been widely recognized and we were invited to contribute to the international consensus paper on the function of the IN (Chapter 6).

The second and most important part of this dissertation research focused on one of the main tenets of the cerebellar learning hypothesis – on the role of the inferior olive in the acquisition of conditioned eyeblinks. We made major progress in addressing this issue. First of all, we developed a new conditioning paradigm that utilizes a vibrissal stimulation CS and produces learning that is significantly faster than that attained using more traditional CS modalities (Chapter 2). Because this paradigm offers unique advantages in acquisition studies that interfere with the operation of eyeblink networks by microinjecting drugs, we

used it our main experiment. In our main experiments we examined the role of IO teaching signals in learning by blocking them with a glutamate antagonist during vCS acquisition. We discovered that contrary to predictions of the cerebellar learning hypothesis, injecting CR-abolishing and presumably US-blocking doses of a glutamate antagonist in the IO did not prevent learning. This indicates that the putative cerebellar learning mechanism is extremely robust because it can withstand the IO manipulation-induced changes of spontaneous firing in the cerebellar cortex and nuclei. More importantly, perhaps in this mechanism the mossy fiber information about both the US and CS is sufficient to induce learning. We expect that our finding will have a major impact on concepts explaining the mechanisms of eyeblink conditioning.

As outlined in Chapter 3, the possible role of the IO in eyeblink conditioning has not been resolved completely. Future electrophysiological studies are required to confirm or to disprove our conclusions. Recognizing this situation, we initiated preliminary experiments to address this problem (Chapter 4). In this pilot study, we developed a single-unit recording system suitable for isolating and holding single unit Purkinje cell activity for the full duration of an injection experiment involving an IO glutamate antagonist. Data acquired thus far indicate that CR-abolishing doses of DGG administered to the IO indeed block IO signals. In the future, this study will have to be expanded to collect a representative sample of Purkinje cells from cortical eyeblink microzones and also to examine the time profile of the IO signal block.

Another logical implication of this research for future studies is the question of CS specificity. Could it be that our conclusions are limited to the acquisition of vCS-evoked

CRs? This question should be addressed in studies that will block glutamate-mediated IO signals in animals being conditioned to other CS modalities.

Depending on the outcome of these two groups of future studies, we envision two scenarios. It is possible that our finding will be further substantiated and that the hypothetical role of IO teaching signals will be falsified. In this case, future studies will have to focus on explaining how the mossy fiber CS and US signals contribute to learning. On the other hand, we cannot exclude that it will be found that our results are attributable to an incomplete block of IO signals. In that case, future studies will have to focus on devising a better approach to completely blocking IO task-related signals while simultaneously not perturbing the functional state of eyeblink networks.

ACKNOWLEDGEMENTS

Completing my doctoral degree is a major achievement. Although a PhD is a lot of personal work, obtaining this degree is a product of a lot of teamwork involving many people. I obviously cannot describe in detail how much I appreciate all of the people involved in this process because I would have another full-length dissertation. But I would like recognize a select few and start with a couple of individuals involved in the “daily grind” of my PhD studies.

Dr. Bracha spent hundreds of hours (possibly more like thousands of hours) teaching me how to be a scientist. This training involved many things, from methods to conduct proper experiments and neurosurgeries to interpreting and understanding the acquired data. This training will serve me well in my future scientific endeavors. However, most importantly, he has changed the way I think. I frequently find myself analyzing everything I do from a scientific/philosophical perspective, whether it's a mundane, daily-life event or something more important and I am convinced he has a large role in this aspect of my life. Finally, beyond his scientific and analytical training, I must thank him for his time. I can remember numerous mornings in my five years in which he came to the lab to discuss some data but stayed for hours because the discussions turned into much more than just results. Whether they were scientific, philosophical, political or some other random topic, many of these discussions I remember like they occurred yesterday. All professors are busy and I have heard about very few who are willing to devote so much time to their students and for that, I am eternally grateful.

The other person I must thank for his daily assistance is Gary Zenitsky. Gary was instrumental in the operations of the lab and in my training. Gary was always willing to work however much is necessary to accomplish the task at hand. This was a huge advantage for the lab in general and for me personally, to help meet deadlines, such as finishing this dissertation. He played a pivotal role in the content provided in this dissertation. Gary taught me a great deal about science and data collection also. He is a meticulous note-taker, always willing to offer any advice (in a good way 😊), and is the resident expert on statistics. There is no question that more of my knowledge about statistics is from him than any class I've taken on the subject. All of these factors are reasons why I consistently tell him that I will be hiring him as my lab manager in the future and he doesn't really have choice in the matter. He is a wonderful colleague, but more importantly, a great friend.

Next, I want to thank the members of my committee that were willing to help in my scientific training; Dr. Bracha, Dr. James Bloedel, Dr. Tim Day, Dr. Donald Sakaguchi, and Dr. Ann Smiley-Oyen. Dr. Bloedel also served as my mentor for the Preparing Future Faculty program. I have spent many hours talking with him about life as a faculty member and many of the things we talked about will benefit me greatly in the future. Dr. Day, who also served on my master's committee, has also been a great resource for advice on academic life. In addition, the coaching I have received from him during our noon basketball games in the IBL was a giant asset to improving my basketball game 😊. I had a lot of interaction with Dr. Sakaguchi through his huge involvement in the Neuroscience journal club and seminars. As I got closer to the end of my PhD, I started to really appreciate the amount of work I witnessed from Dr. Sakaguchi in his efforts to keep improving the Neuroscience program

here at ISU. He has worked very hard and seems to genuinely care about the education of the Neuroscience doctoral students. I will always remember the often-used line of “surely there are more questions” towards the end of journal club classes. We have laughed about it together at social events but in my opinion, it should remain a vital part of journal club when the class needs a little boost. Finally, Dr. Smiley-Oyen has been part of my entire graduate school experience. She was my advisor for my master’s degree and has been actively involved in my PhD. I couldn’t have asked for a better advisor and person to start my graduate training back with her in 2005. I have always enjoyed our discussions over the years and she is a tireless educator. She taught me an enormous amount about how to be a better teacher and researcher.

Another person that provided me with a lot of advice and guidance is Dr. Svitlana Zbarska. When I first started in the lab, Svitlana was responsible for training me in many of the techniques and methods used in the lab, especially surgery training. She spent a large amount of time with me in those initial months of training and we also discussed a lot of literature. I thank her for being willing to do so.

I also want to thank some additional people in the Biomedical Sciences department, starting with Kim Adams, Linda Erickson, and Bill Robertson. They are an integral part to anyone in the department and always made my life much easier. Two additional faculty that I was lucky enough to spend a lot of time with were Dr. Steve Carlson and Dr. Etsuro Uemura. Dr. Carlson has also given me so much advice on faculty life and life outside of work. He also taught me that no matter how busy one gets in his/her work, it’s okay to take some time and go exercise☺ This was a unique piece of advice and has actually served me

very well. Dr. Uemura is the professor-in-charge of the neuroanatomy class in which I was the TA. I absolutely loved my time spent with him those two spring semesters. He taught me so much about being a teacher and we had some terrific discussions.

Last but certainly not least, I want to thank my parents and my wife. When thinking about what I've accomplished so far in my life, none of it would have occurred without the love, support, and encouragement from my parents. My work ethic and motivation comes from seeing them work extremely hard to provide everything I needed while growing up and sacrificing some of their wants and desires in order to enable me to do so many things. I would not be who I am today without their never-ending support.

I am forever in debt to my wife, Denise. She dealt with the long working hours and my occasional grouchiness as a result of PhD-induced stress and sleep deprivation. She made obtaining this degree exponentially easier with her assistance in everything she could do to make it easier on me. I hope someday that I can find a way to return the favor.

This dissertation is dedicated to my sister, Alison, who left all of those who knew her with a void in their lives that will never be filled.